



Mini Sigma On-line



Mini Sigma Angle

Registered Patent

Disclaimer

Copyright © 2018 Amiad Water Systems Ltd. All rights reserved.

The contents of this document, including without limitation all information and materials, images, illustrations, data, drawings, names and any other such materials that appear in this document are the sole property of Amiad Water Systems Ltd., including any intellectual property rights, whether registered or not, and all know-how contained or embodied therein. Amiad may alter, remove or change the Content without any further notice. You may not reproduce, copy, modify, create derivative works from, sell or participate in any sale of, or exploit in any way, in whole or in part, any of this document or its content.

The confidential nature of and/or privilege in the file enclosed is not waived or lost as a result of a mistake or error in this file. If you received this file in error, please notify Amiad immediately at info@amiad.com.

This document does not replace any certified drawing, procedure or information provided by Amiad in reference to a specific customer, site or project.

Amiad assumes that all users understand risks involved within this file and/or its attached materials. This document is given in good faith and is not intended to impose any obligation to Amiad. While every effort has been made to ensure the information in this manual is accurate and complete, we would appreciate if you can bring any errors or omissions to the knowledge of Amiad or consult Amiad experts or its authorized representatives if you have any questions.

Amiad Water Systems Ltd. D.N. Galil Elyon 1, 1233500, Israel Tel: 972 4 690 9500 | Fax: 972 4 814 1159 Email: info@amiad.com

Table of Contents

Disclaimer	1
Table of Contents	2
Legend	3
Mini Sigma Family.....	4
Technical Specifications.....	5
Dimensional Drawings - On-line Configuration.....	6
Dimensional Drawings - Angle Configuration.....	7
General Safety Instructions	8
Installation.....	9
Changing Installation Configuration	13
Initial Operation.....	19
Maintenance.....	20
Winterization.....	20
Basic Maintenance - Disassembly	22
Basic Maintenance - Assembly	28
Valve and Cylinder Maintenance.....	34
Bill of Materials – 2" On-line	43
Bill of Materials – 2" Angle	44
Bill of Materials – 3" On-line	45
Bill of Materials – 3" Angle	46
Bill of Materials – 4" On-line	47
Bill of Materials – 4" Angle	48
Control Schematic	49
Troubleshooting	50
Amiad Limited Warranty	51

Legend



Push



Pull



Screw



Unscrew



Measure



**Water
pressure**



Attention



Apply



Caution



Read



Center



**Sigma
multi-tool**



Rotate

Mini Sigma Family

2" Angle



3" Angle



4" Angle



2" On-line



3" On-line



4" On-line



Technical Specifications

General data	2" Mini Sigma	3" Mini Sigma	4" Mini Sigma
Max. flow rate* (130μ) in average water quality	30 m ³ /h (132 gpm)	50 m ³ /h (220 gpm)	80 m ³ /h (352 gpm)
Min. operating pressure when cleaning	1.5 bar (22 psi)		
Max. operating pressure	8 bar (116 psi)		
Max. operating temperature	60°C (140°F)		
Filtration area	1200 cm ² (186 in ²)	1600 cm ² (248 in ²)	2400 cm ² (372 in ²)
Inlet/Outlet diameter	2" (50 mm) BSPT/NPT	3" (80 mm) Grooved Coupling / Universal flange	4" (100 mm) Grooved Coupling / Universal flange
Weight (Empty)	16 KG (35 lb)	20 KG (44 lb)	23 KG (51 lb)

* Amiad's flow recommendation per water quality.

Electronic control	
Control power supply	4 X AA type 1.5V batteries / External 7-14V DC
Solenoid operation data	12-9V DC latching solenoid
DP switch	Integral sensors

Flushing data*			
Exhaust valve	1.5" (40mm) BSPT/NPT		
Flushing time	10 seconds		
Reject water volume per flush cycle	24 liters (6.3 gallons)	26 liters (6.8 gallons)	28 liters (7.4 gallons)
Flushing flow rate	8.7 m ³ /h (38.3 gpm)	9.6 m ³ /h (42.2 gpm)	10 m ³ /h (44 gpm)

*At 1.5 bar (22 psi).

Construction materials	
Filter housing and lid	RPA (reinforced polyamide)
Screens	Molded weavewire stainless steel 316L
Cleaning mechanism	PBT (Polybutylene)
Exhaust valve	All Polymeric
Seals	EPDM
Control command tubing	PE (Polyethylene)

Standard Filtration Degrees						
micron	500	300	200	130	100	80
mm	0.5	0.3	0.2	0.13	0.1	0.08

Dimensional Drawings - On-line Configuration

2" On-line

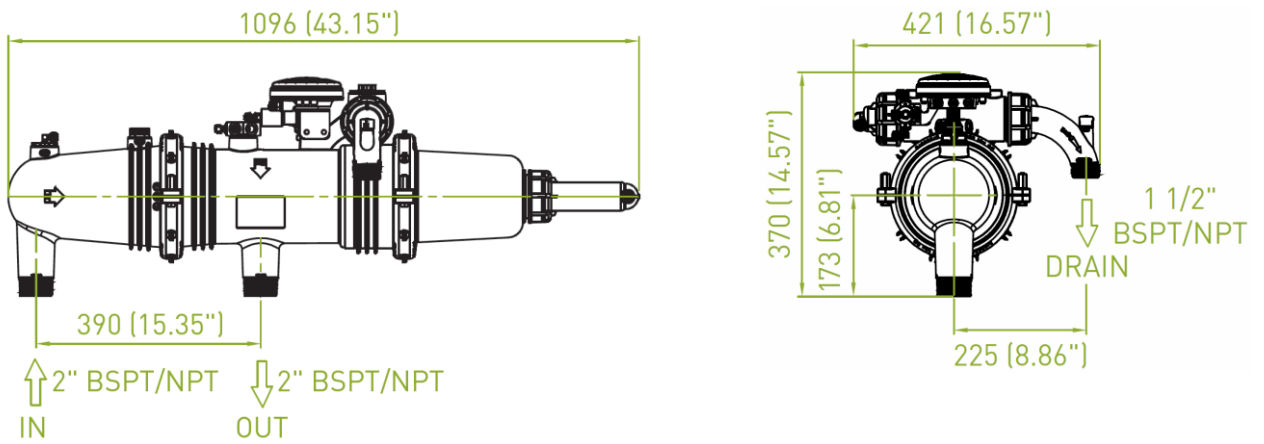

3" On-line

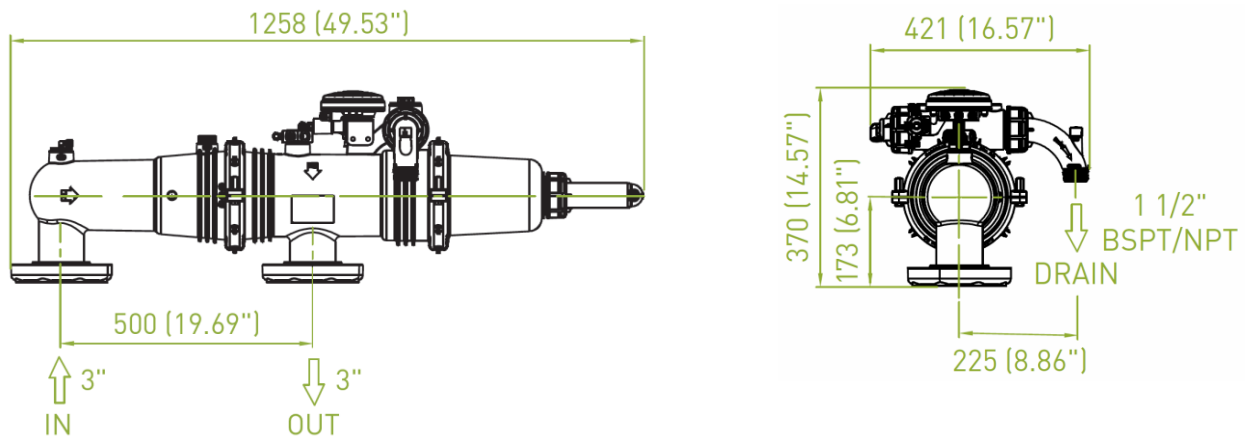

4" On-line

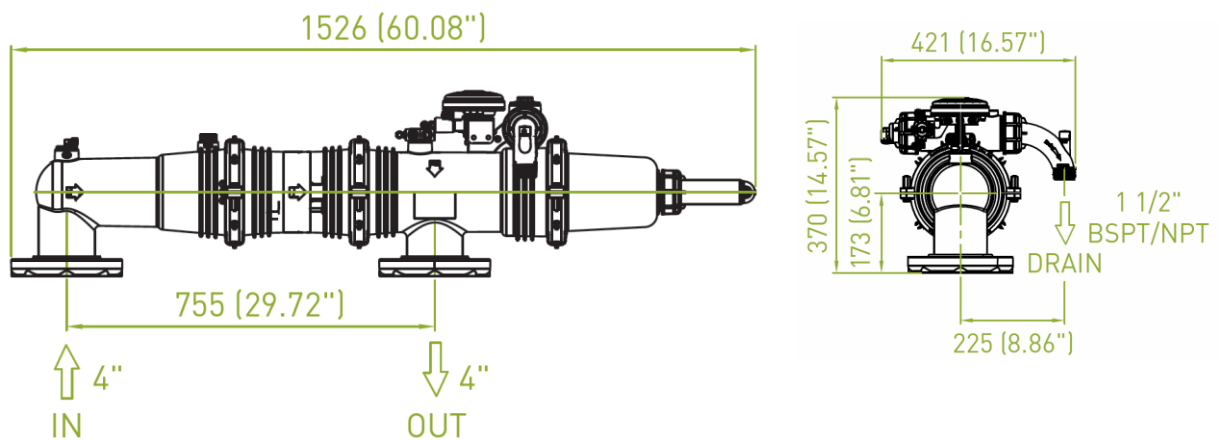

Dimensional Drawings - Angle Configuration

2" Angle

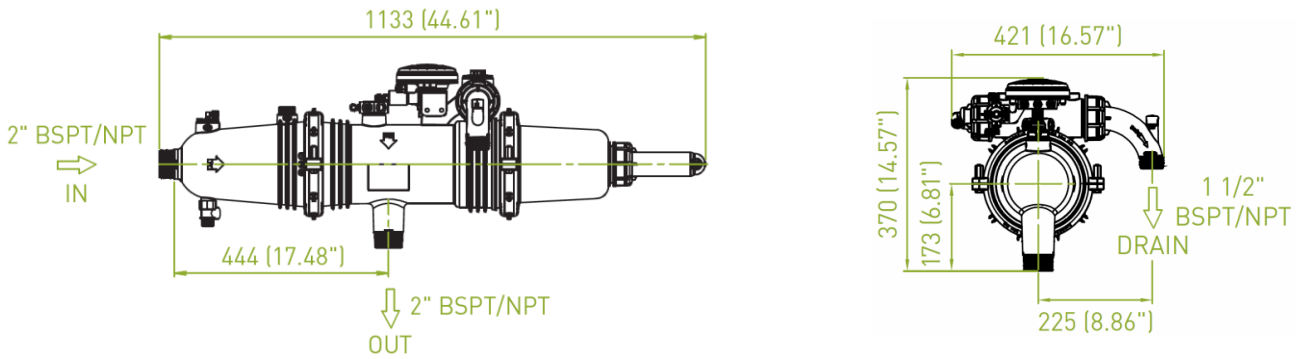

3" Angle

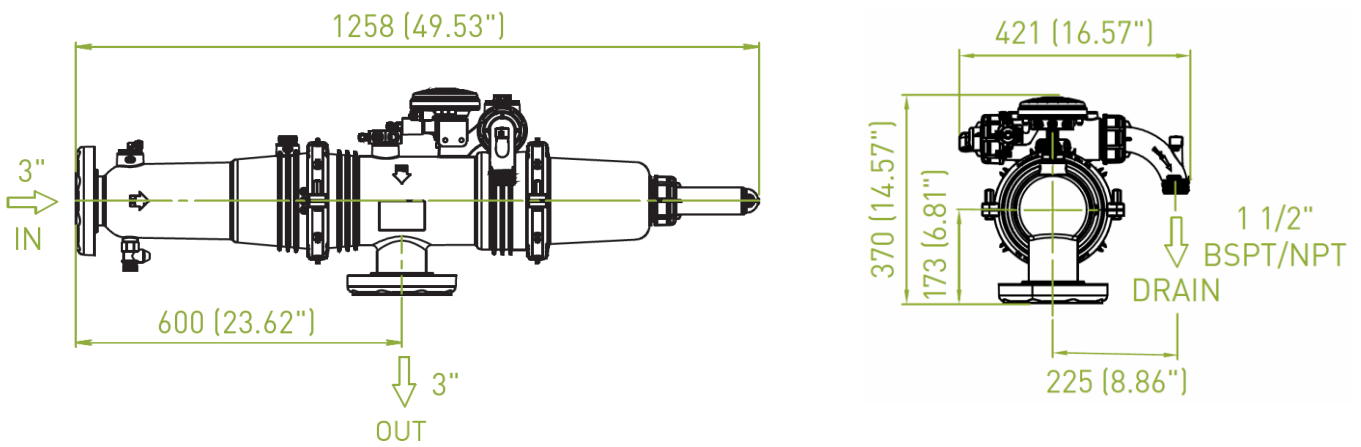

4" Angle

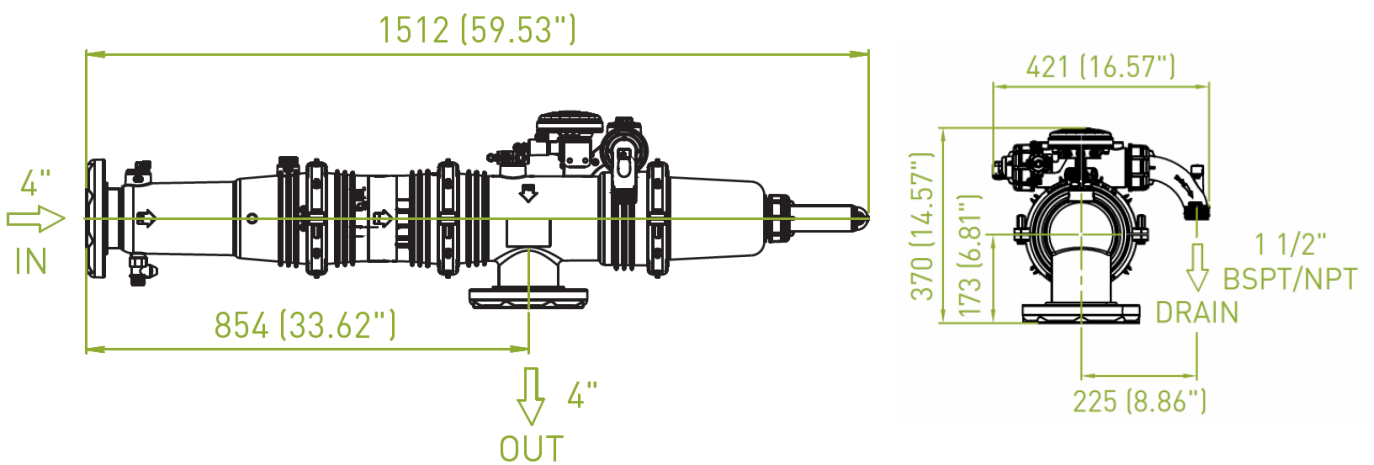

General Safety Instructions

- Amiad Water Systems Ltd. ("Amiad") filtration products operate as components in a larger system. It is essential for the system designers, installers, and operators to comply with all the relevant safety standards and regulations, including the use and wear of appropriate safety equipment.
- Prior to installation, operation, maintenance, or any other type of action carried out on the filter, carefully read the safety, installation, operation, and warranty instructions.
- During installation, operation, commissioning, or maintenance of the filter, all conventional safety instructions should be observed to avoid danger to any person, including the workers performing the said activity, or to property in the vicinity.
- Please note: the filter enters a flushing mode automatically, without warning.
- Manual cleaning of filter element using high water pressure or steam should be performed in accordance with the cleaning system instructions, the local standards, and regulations.
- Manual cleaning of filter element using acid or other chemical agents should be performed in accordance with the relevant material safety instructions, the local standards, and regulations.

Observe and act according to the requirements detailed in the safety stickers on the filter, if any.

Installation

General

- Install the filter according to the detailed Installation Instructions provided with the filter by Amiad included in this manual.
- Minimum spacing above the filter should be 30cm (12").
- Tighten all bolts during commissioning and after the first week of operation.
- Use only appropriate or recommended tools and equipment when servicing the filter.
- Shipping and transporting the filter must be done in a safe and stable manner and in accordance with the local standards and regulations.

Hydraulics

- We recommend installing a manual water cut-off valve next to the filter's inlet port.
- In cases where the piping network is downstream, and the filter is pressurized, an additional manual water cut-off valve should be installed next to the filter outlet port.
- We recommend that the system includes a pressure release / drainage valve to enable release of residual pressure prior to any maintenance procedure. It is recommended to add an air release valve.
- Ensure that the filter is not exposed to water pressure that exceeds the maximum pressure defined by Amiad. If needed, a pressure reducing valve should be installed upstream of the filter.
- Please note that the maximum working pressure indicated in the filter's specifications table includes the pressure caused by water hammer and pressure surge effects.
- If possible, prior the installation, thoroughly flush the main line at the connection point to remove large objects that may damage the filter's internal mechanism.

Recommended tools for installation



**Two 13 mm (1/2")
wrenches**



Cutter



Philips screw driver



Sigma multi-tool
710101-001280
*supplied by Amiad

Unpacking

1. Remove the eight (8) screws and four (4) plastic clips from the package

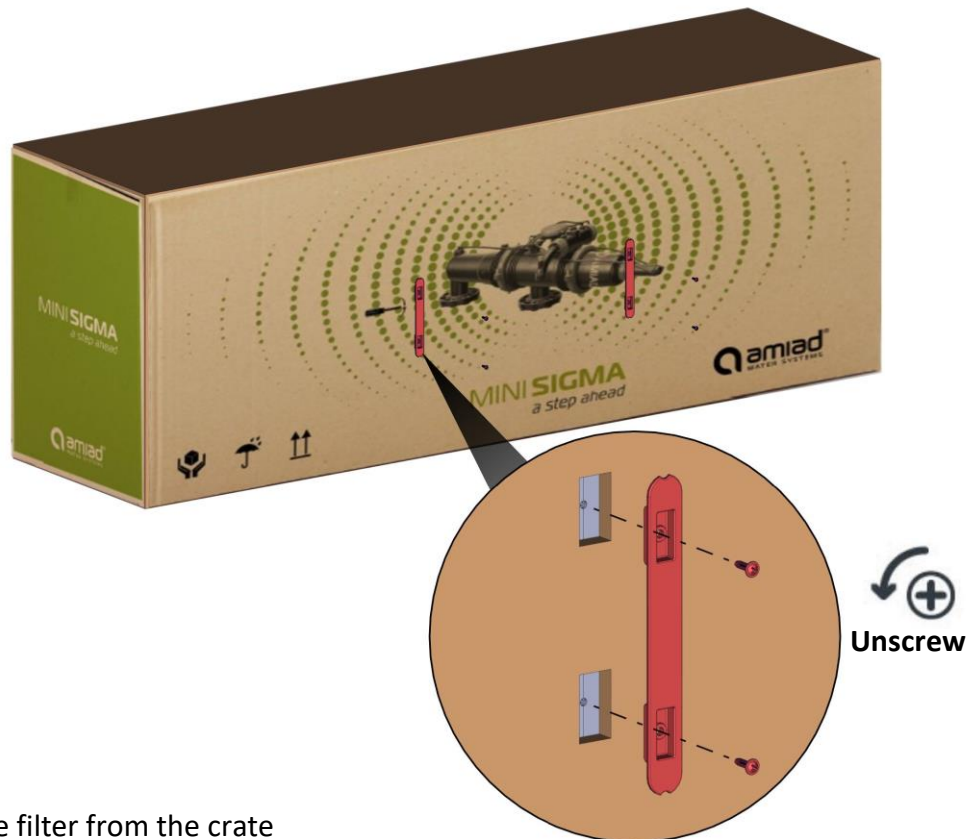

2. Remove the filter from the crate

Note: Sigma multi-tool and drainage pipe are attached here, for your use

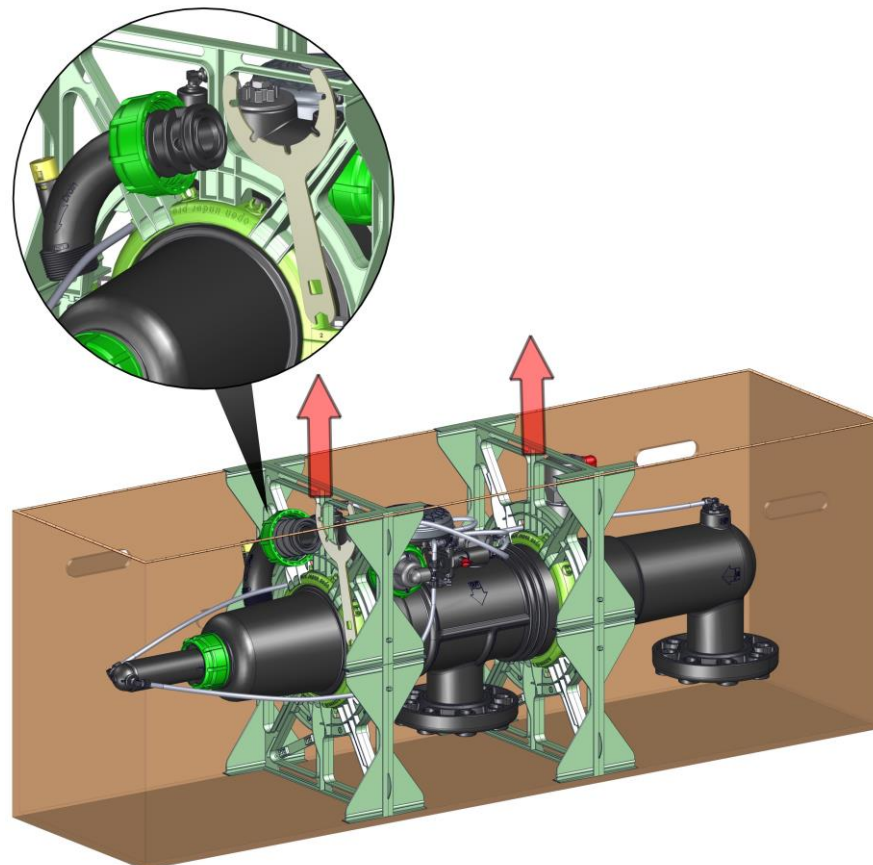

3. Remove the plastic holders from the filter

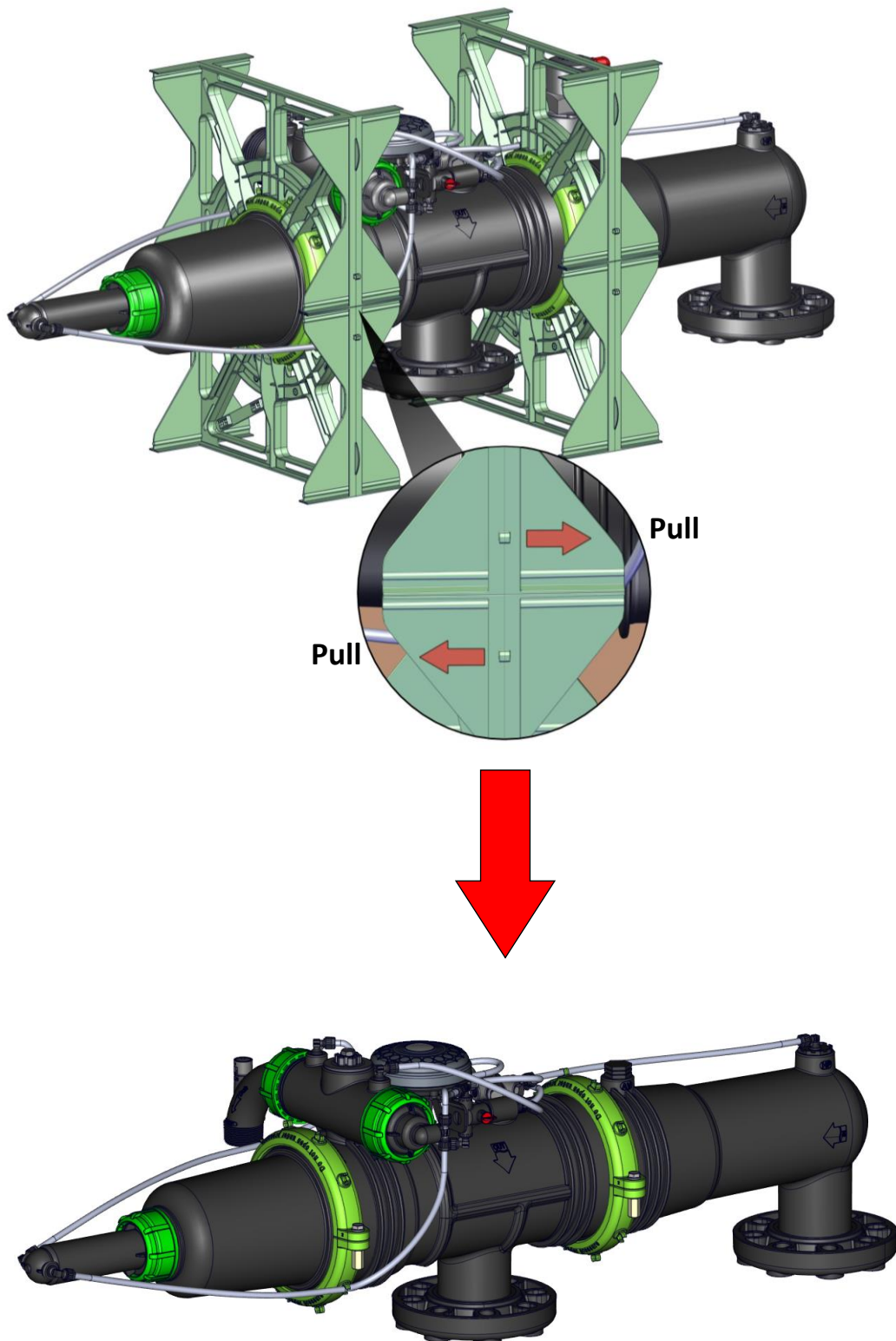

Installation

Connect the inlet and outlet ports according to the installation configurations described below:

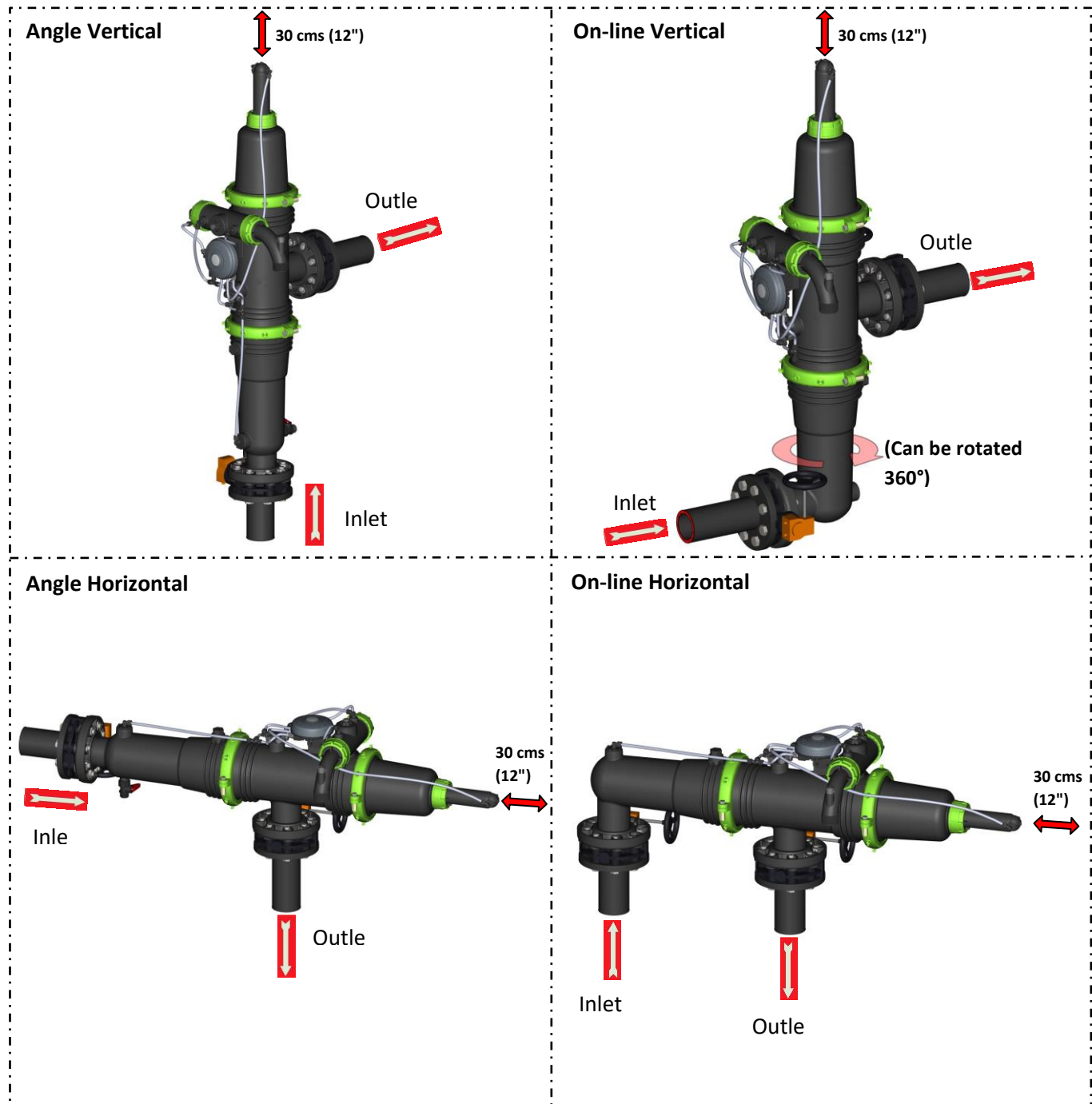

Note:

Ensure that the direction of the flow is aligned with the arrows marked on the filter housing.
To prevent static backpressure or reverse flow through the filter,
it is recommended to install a non-return valve.

Changing Installation Configuration

Changing the inlet direction:

If the original configuration does not match the required installation position, the lower body can be rotated 360°.

In order to change the configuration of the filter (according to the table above), follow these steps:

1. Disassemble the filter according to the basic disassembly procedure on page 22
2. Disconnect the command tubes from the Sigma lower body
3. Remove the clamps according to the following steps:
 - a. Unscrew the bolts on both sides of the clamps, using two 13 mm (1/2") wrenches
 - b. Remove both clamps

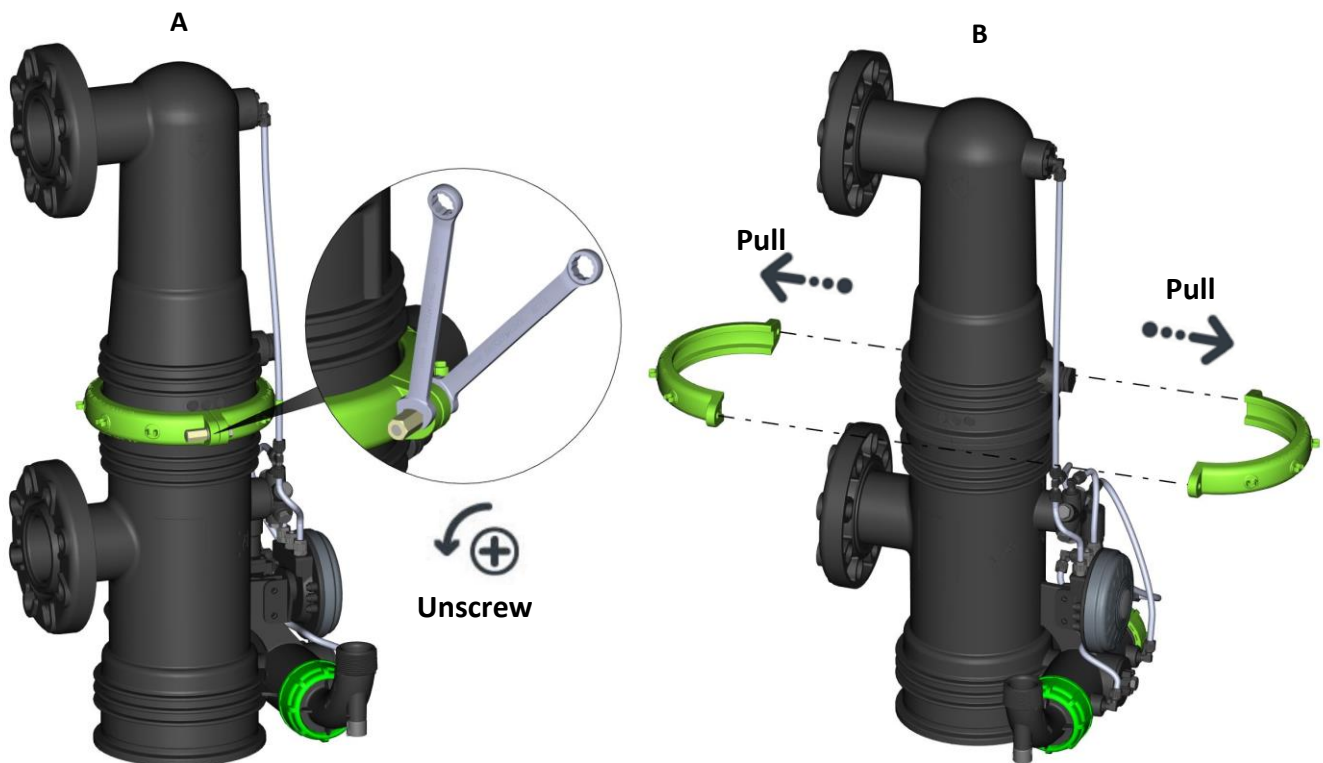

4. Remove the lower body from the upper body

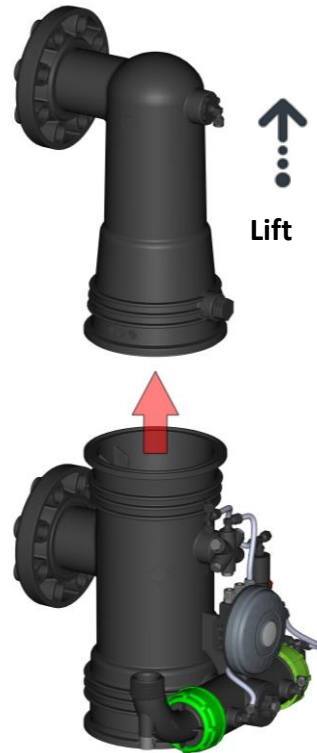

The installation configuration can be changed by rotating the lower body 0° - 360°

5. Rotate the lower body to any desired position (for example: 90° or 180° as shown below)

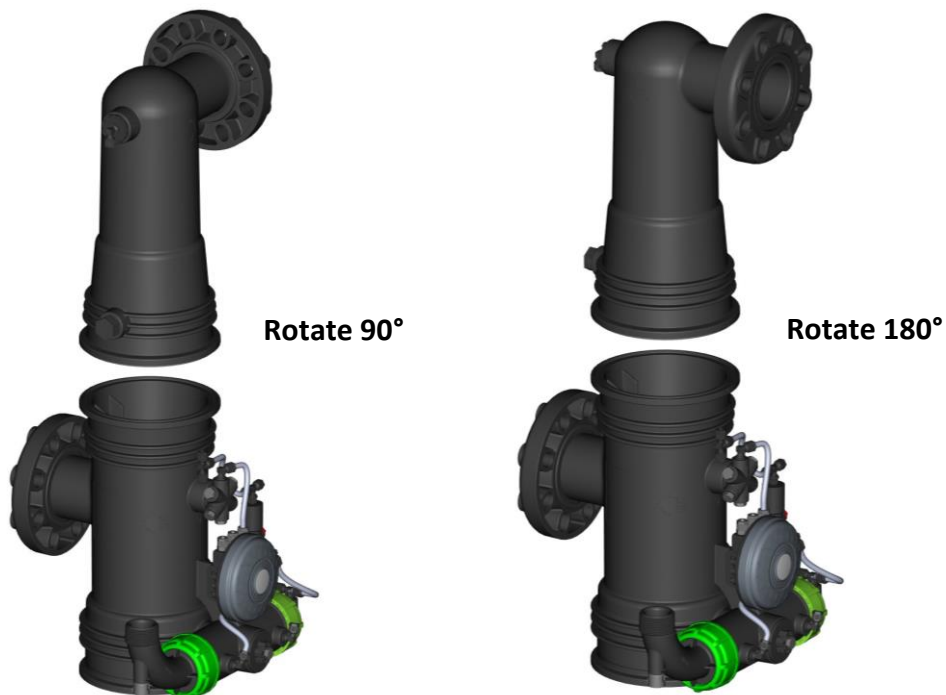

6. Reconnect the upper and lower bodies:
 - a. Place the clamps on the filter
 - b. Screw the bolts on both sides of the clamps, using two 13 mm (1/2") wrenches
 - c. Connect the lower body command tubes



7. Continue the installation process according to the basic assembly procedure on page 28.

Changing the drain pipe outlet direction:

Note: Ensure that in all assembly configurations the drain pipe outlet faces toward the ground (the drain pipe can rotate 360°).

The drain pipe can be connected on both sides of the filter and can rotate 360°. In order to change the drain pipe side, follow the instruction on chapter Valve and Cylinder Maintenance on page 34.

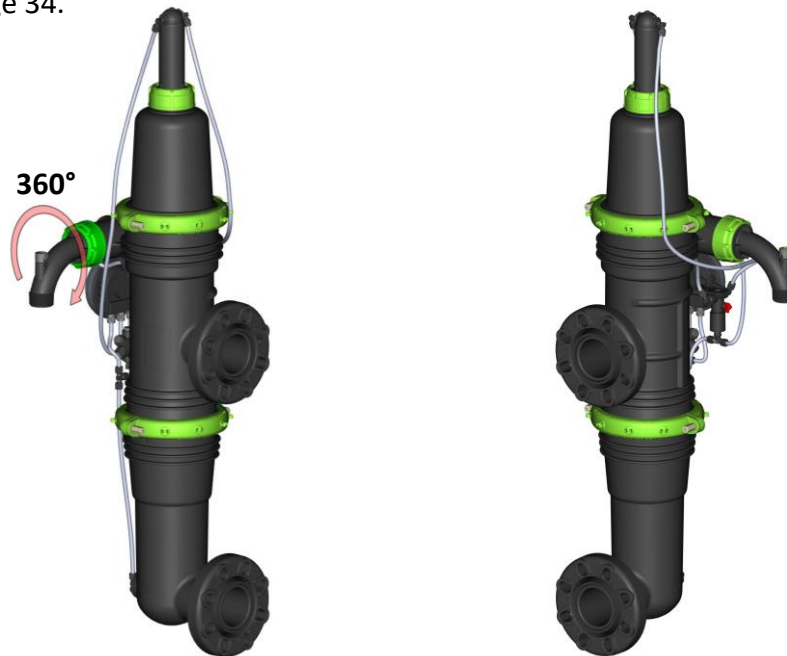

In order to change the configuration of the drain pipe follow these steps:

1. Open the nut a quarter turn

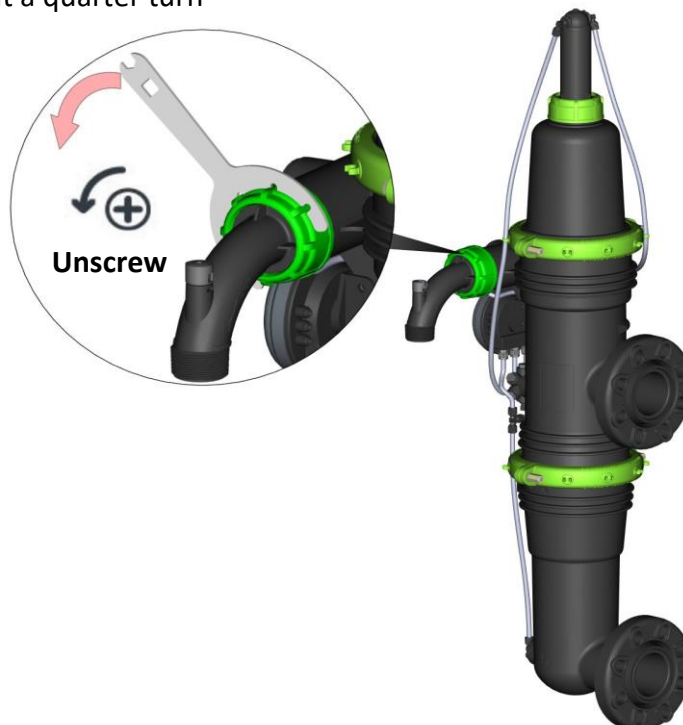

2. Rotate the drain pipe to the desired direction



3. Tighten the nut

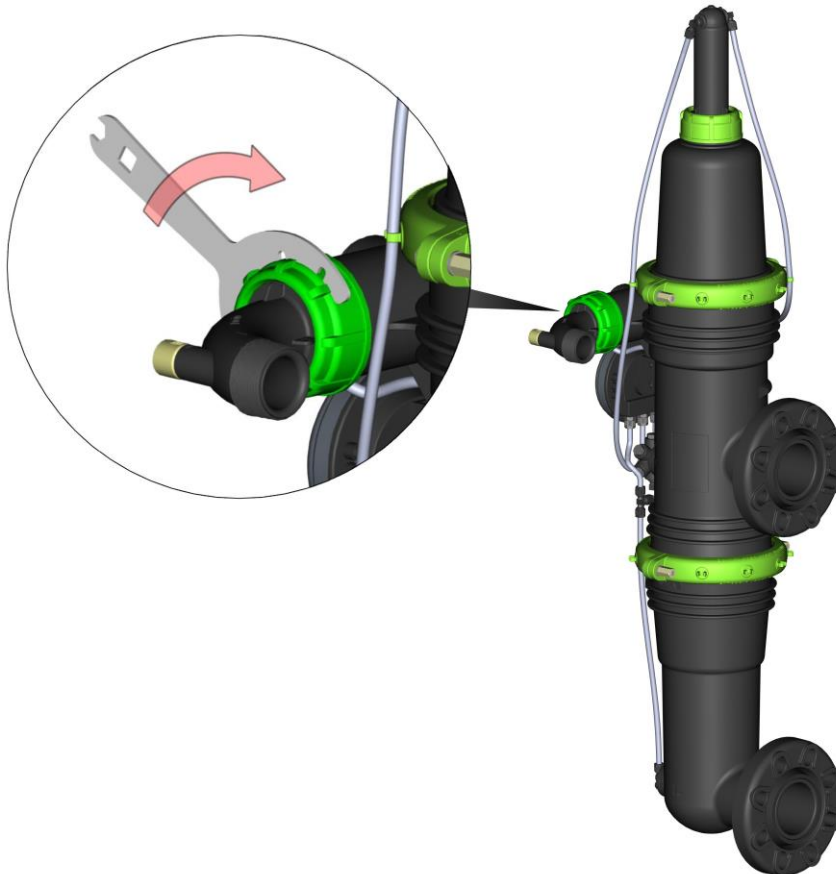

Universal flange replacement (Optional)

The universal flange can be removed, it is possible to connect the filter by a grooved connector.

To remove the universal flange, follow these steps:

1. Remove the o-ring
2. Push the flange backward and remove the conical ring

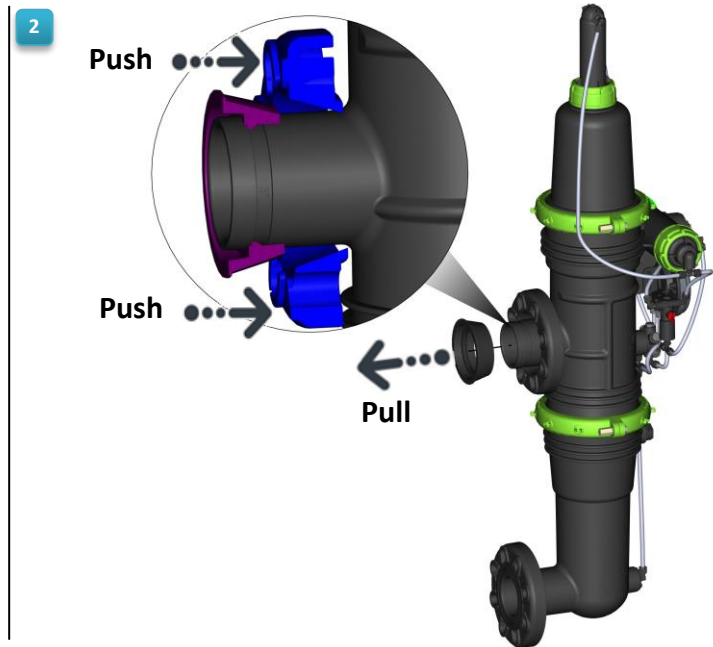
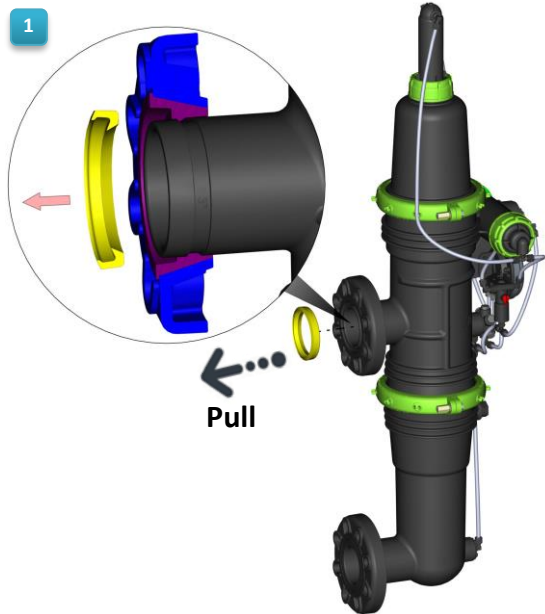

3. Remove the flange from the Sigma body

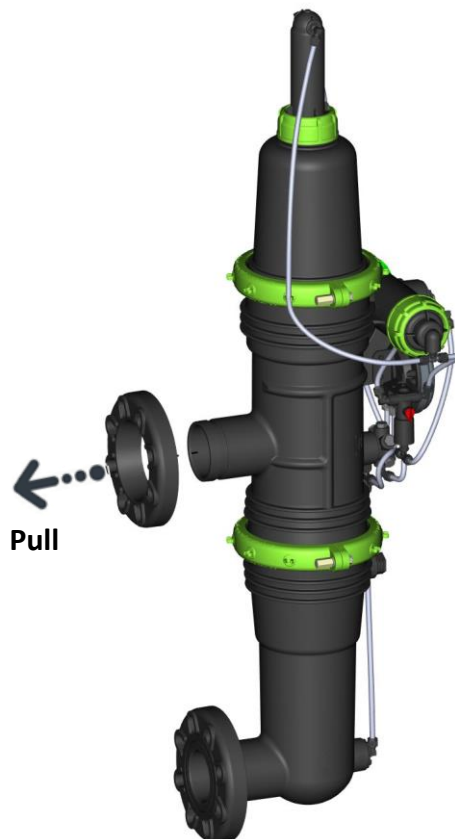

Initial Operation

- Carefully read this operation manual prior to operating the filter.

Note: If flow increases and pressure drops dramatically for a long period of time during network fill-up, it is recommended that a pressure sustaining valve be installed downstream of the filter. The pressure sustaining valve ensures a controlled fill-up of the line.

For initial operation or operation after maintenance, follow these steps:

1. Open the inlet valve slowly while the outlet valve remains closed
2. Open the outlet valve slowly
3. Make sure there are no leaks in the filter
4. Perform a manual flush two times



Maintenance

General inspection:

A general inspection of the filter operation should be done regularly and prior to any scheduled maintenance. This includes pre-season, post-season, and seasonal check-ups.

General inspection procedure:

1. Initiate a self-flushing cycle
2. Check that the exhaust valve opens and closes normally
3. Visually check the filter housing and valves for leakage

Long-term cessation of filter operation

The following must be done if the filter will not be operated for the season:

1. Operate a flushing cycle (if possible, with a closed downstream valve)
2. Release pressure from the filter and drain it

Winterization

To avoid damage or breakage, the filter, including the cylinder and command tubes, must be drained prior to frost periods.

A step by step instructions:

1. Initiate a manual flush to make sure that your screen will be clean for the shutoff period. **Check that the outlet isolating valve is closed and perform two manual rinses.**
2. Close the isolation valves (inlet and outlet).
3. Initiate an additional manual flush to release the pressure inside the filter.
4. If available, open the 3/4" drainage filter body valve (available only on "angle" models).
5. Disconnect the 2 tubes that supply water to the filter piston. (Steps 5-8 see pages 40-42).
6. Release the green nut that tighten the piston in place by using the designated tool that is supplied with the filter.
7. Pull out the piston and drain the water from both the piston and the piston rod.
8. Re-assemble the piston, making sure that the sealing mechanism is in place inside the cylinder (see instructions in the manual or on the piston label).
9. Mark the tubes that are linked to the ADI-P controller and disconnect it from the controller for the duration of the winter season.
10. Dismantle the green clamp that is close to the piston, take off the lid and drain the water from the filter body. Re-assemble and tighten the clamp. (See pages 24-25)

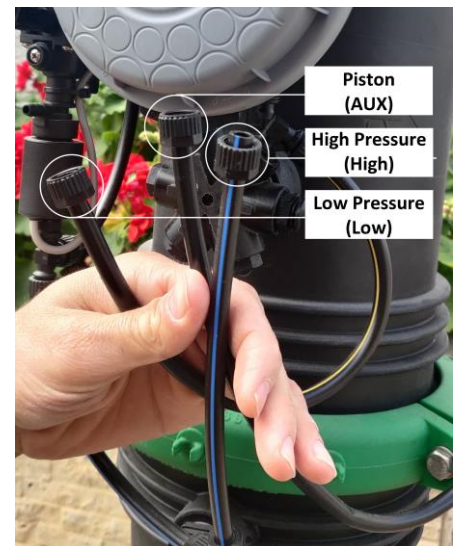

Before any maintenance operation, please read the following:

- Installation, operation, and maintenance should be performed by technicians in accordance with Amiad's instructions and in accordance with this manual. Other service should only be done by authorized technicians.
- Disconnect the filter from the water system by closing and securing the manual inlet valve. In cases where the downstream piping network is pressurized, close and secure the manual outlet valve.
- Release the residual water pressure by opening the pressure release: open the drainage valve (angle) or the high-pressure port (on-line).
- Empty the filter by opening the drainage valve.

Basic Maintenance - Disassembly

Note: Before disconnecting the filter from the water supply and before releasing the filter's residual pressure

DO NOT:

- Unscrew bolts
- Remove any protection cover
- Open any service port flange



Attention

Please note:

Always open and close the valves slowly and gradually!

The filter enters a flushing mode automatically, without warning.



1. Remove the clamps according to the following steps:
 - a. Disconnect the command tubes from the piston cylinder
 - b. Using two 13 mm (1/2") wrenches, unscrew the bolts on both sides of the clamps

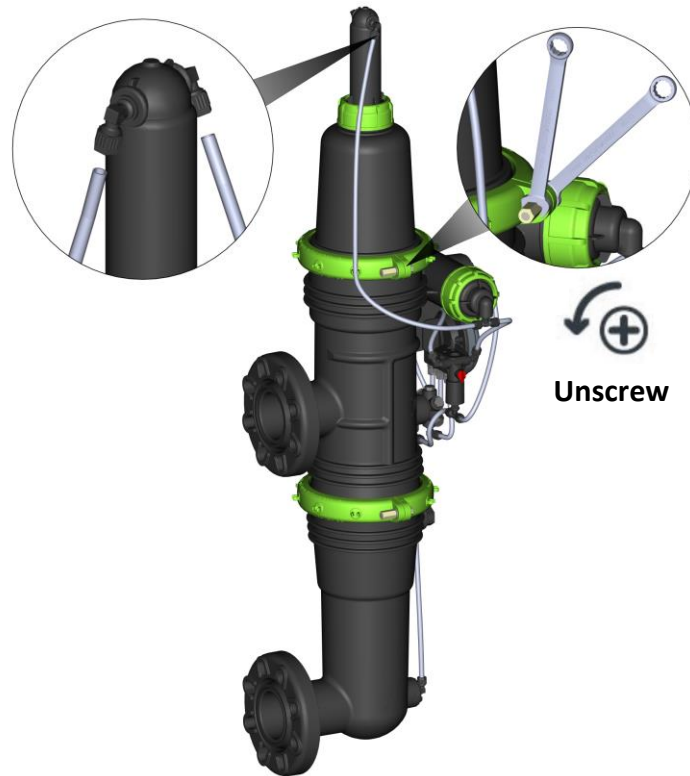

- c. Remove both clamps (hold the filter cover while removing the clamps)

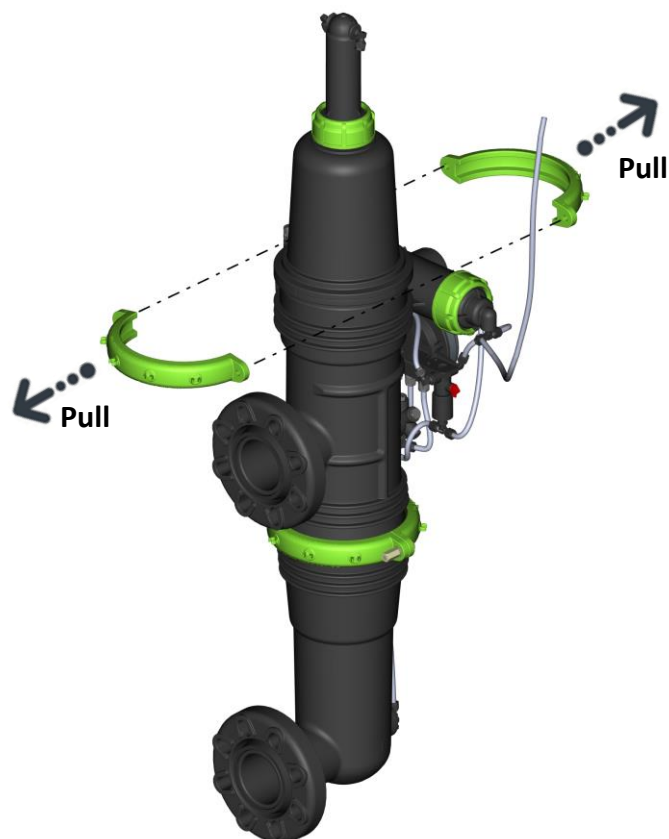

2. Remove the filter cover



3. Remove the turbine



4. Remove the separation plate



5. Remove the scanner and nozzles



6. Remove the screen



7. Before reassembly:

- a. Make sure that all parts below are undamaged
- b. Replace dry or damaged gaskets and o-rings
- c. Make sure that the coarse screen is clean
- d. Apply silicon grease on the o-rings (760190-000127 – tube of grease PG-21)



Clamps

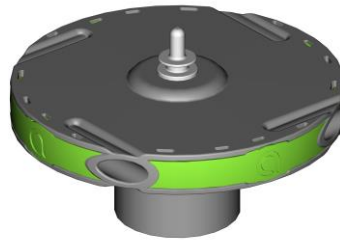

Turbine



Top plate



**Scanner
and nozzles**



Fine screen

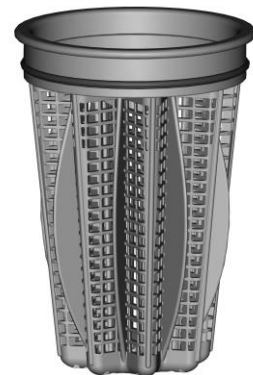

Coarse screen

Basic Maintenance - Assembly

1. Connect the fine screen and coarse screen

Note: Make sure that the o-rings are in place.

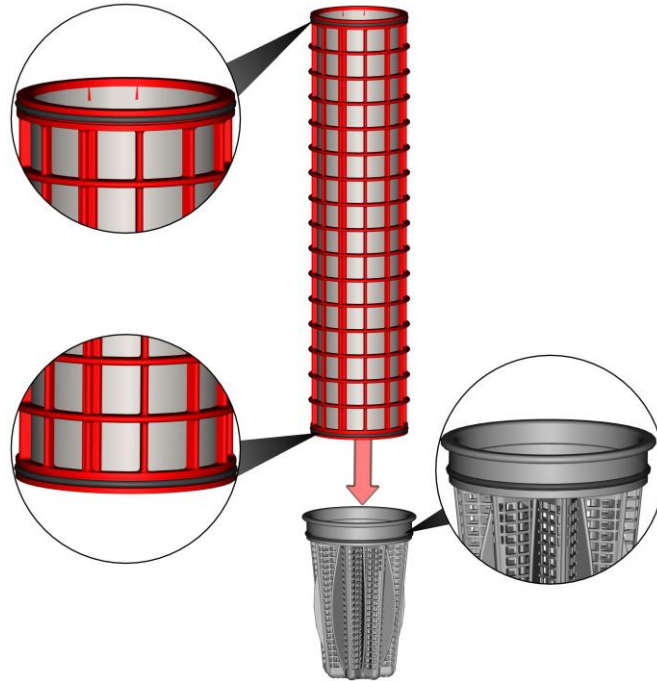

2. Insert the scanner into the fine and coarse screen

Note: Verify that the scanner shaft passes through the socket at the center of the coarse screen.

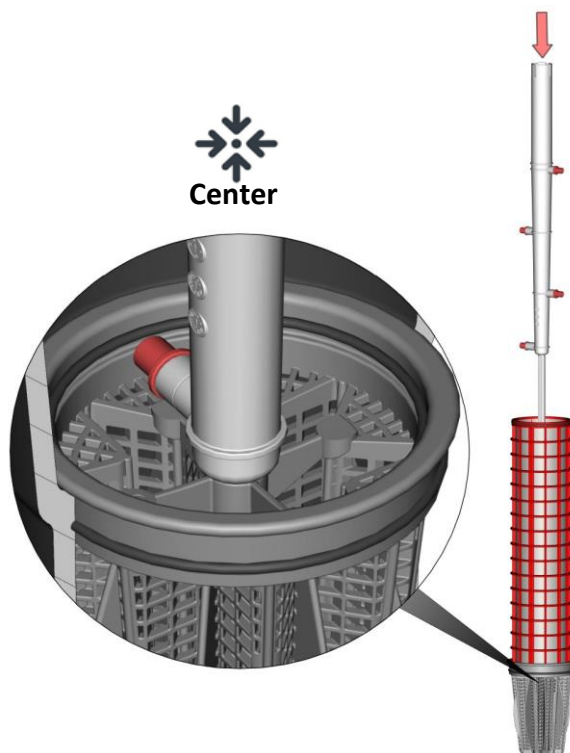

3. Insert the scanner assembly into the filter body



4. Make sure the coarse screen is in place



5. Reinstall the separation plate:
 - a. Make sure the seal is in place
 - b. Apply grease on the seal
 - c. Make sure the seals are intact



Apply



Attention

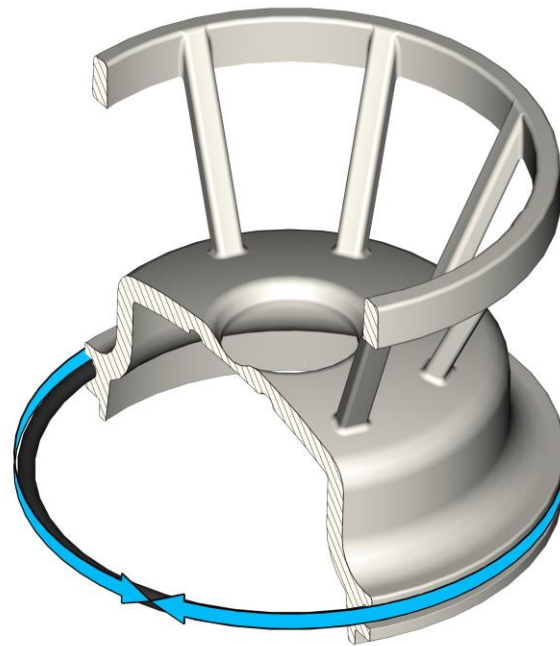

- d. Insert the separation plate into the filter body
- e. Be careful not to damage the seal during plate insertion
- f. Rotate the scanner to ensure that it rotates freely

Push



Rotate



Attention

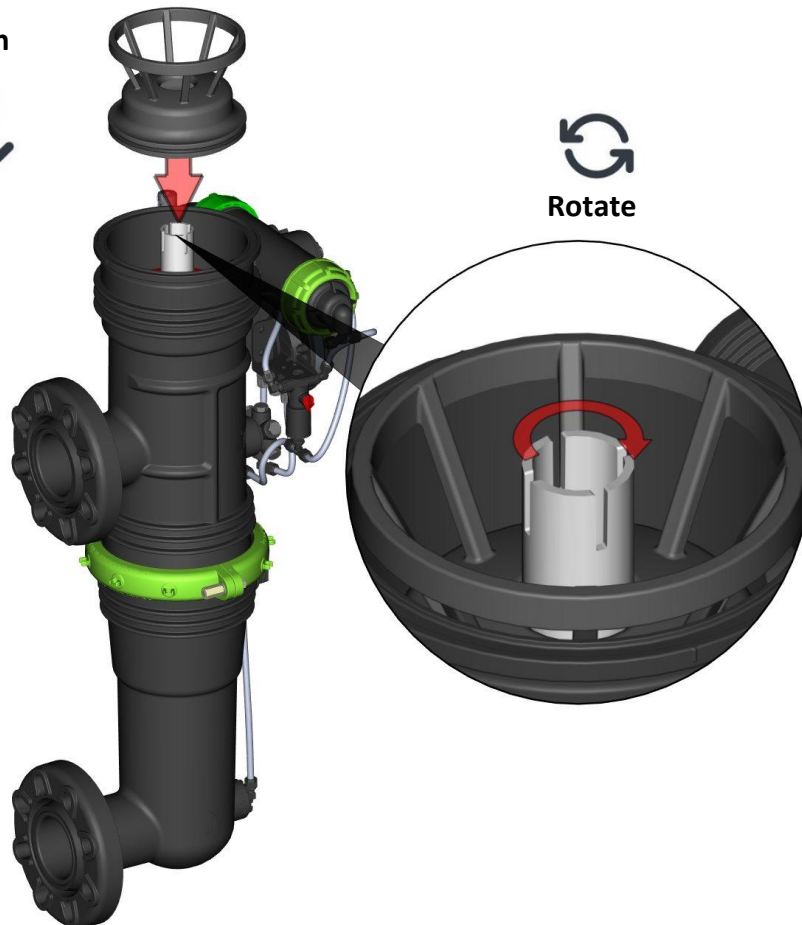

- g. Make sure the separation plate is in place and seals the filter perimeter

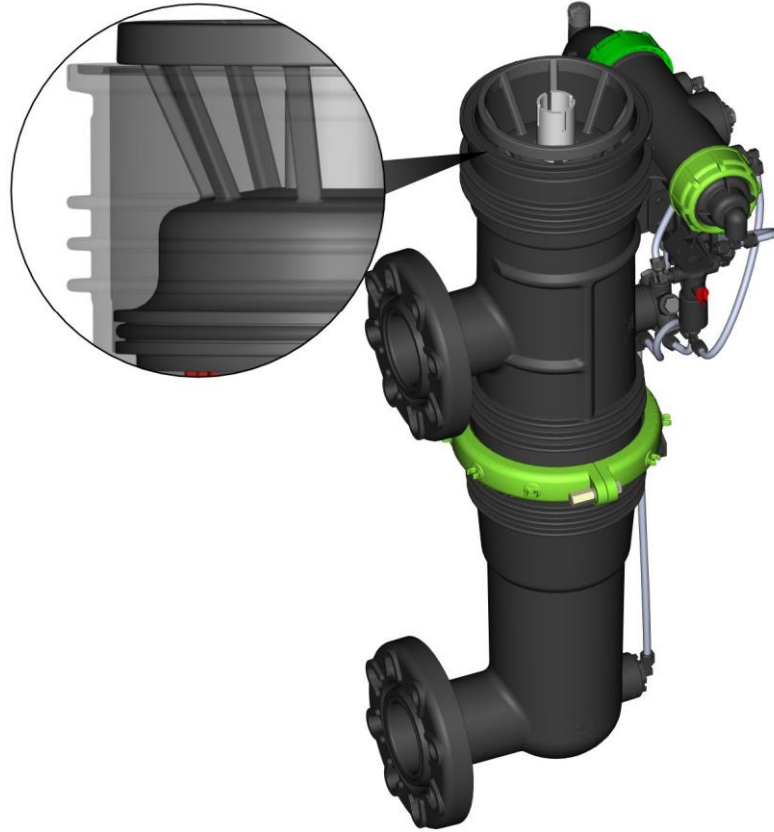

- 6. Insert the turbine, ensuring that the turbine key shaft aligns with the scanner grooves
- 7. Make sure the turbine's bearing is undamaged

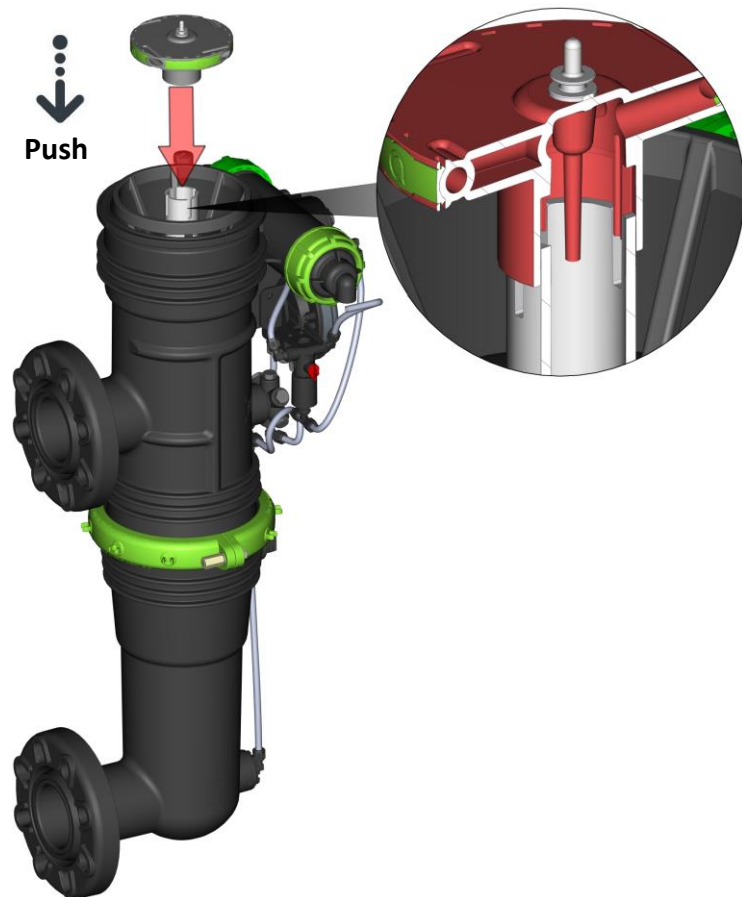

8. Reinstall the filter cover, ensuring that the seal isn't scratched during the process

Note: The guidance lines help to determine the position.

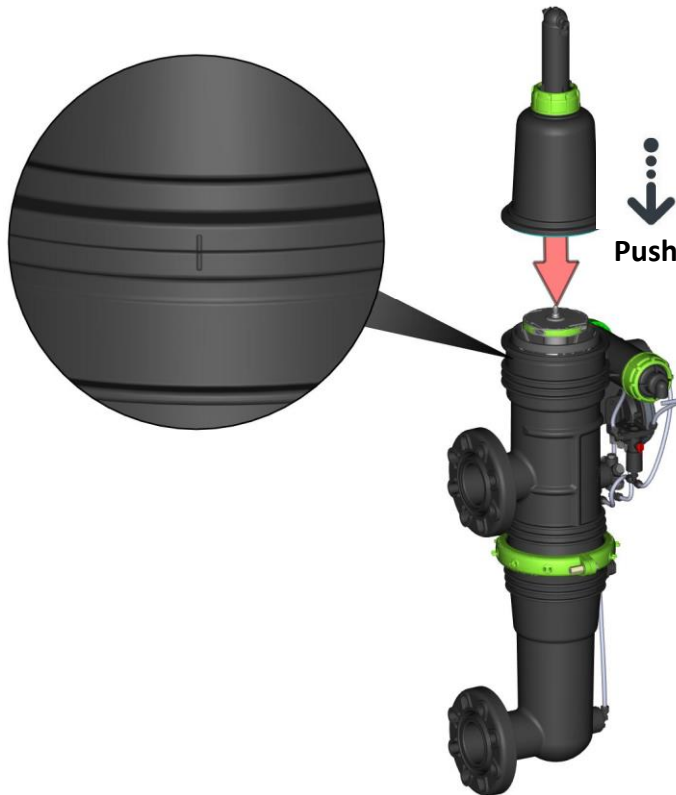

9. Assemble the clamps according to the following steps:

- Place the clamps on the filter
- Screw the bolts on both sides of the clamps, using two 13 mm (1/2") wrenches

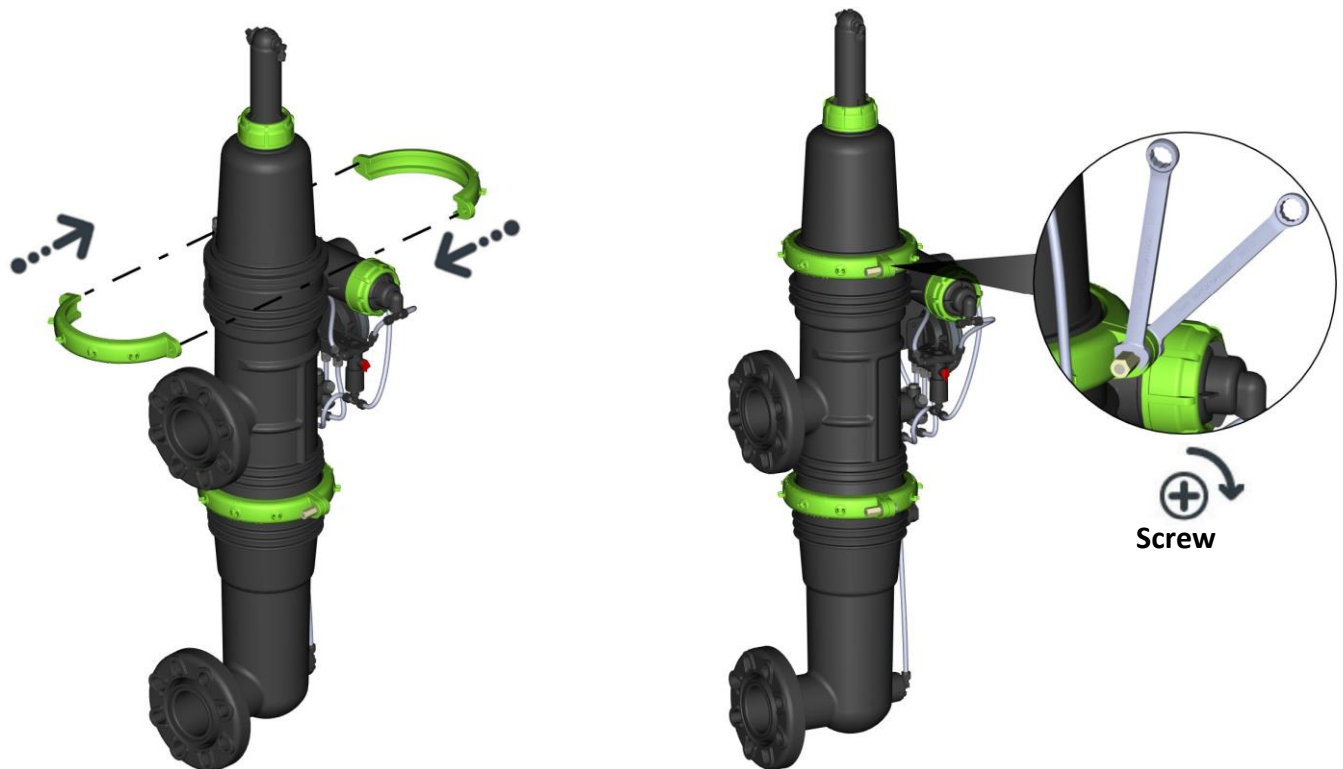

10. Connect the command tubes

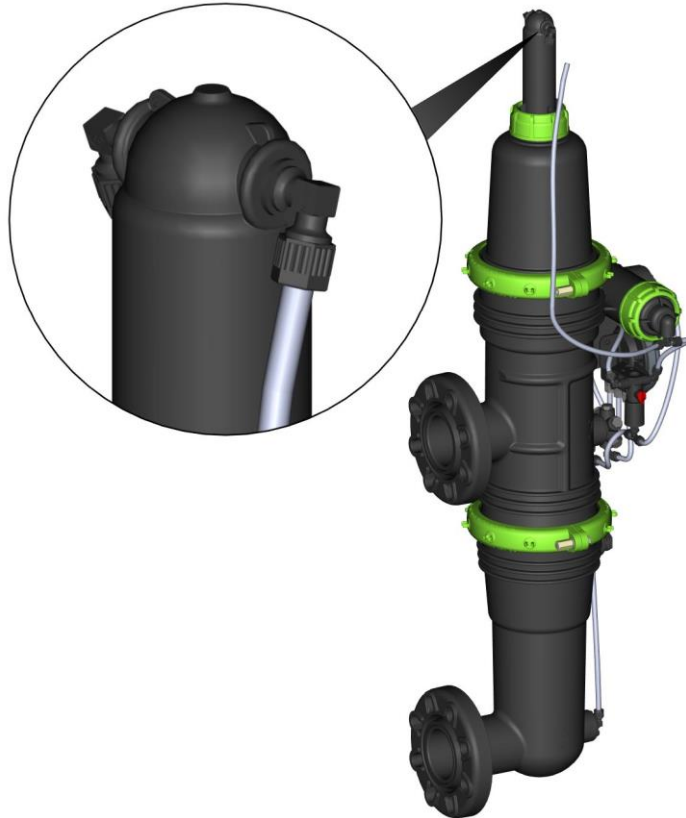

11. Operate the Mini Sigma filter, see page 19



Valve and Cylinder Maintenance

1. Disconnect the drain pipe.
 - a. Make sure that the pressure is low
 - b. Open the nut using the Sigma multi-tool
 - c. Pull out the drain pipe

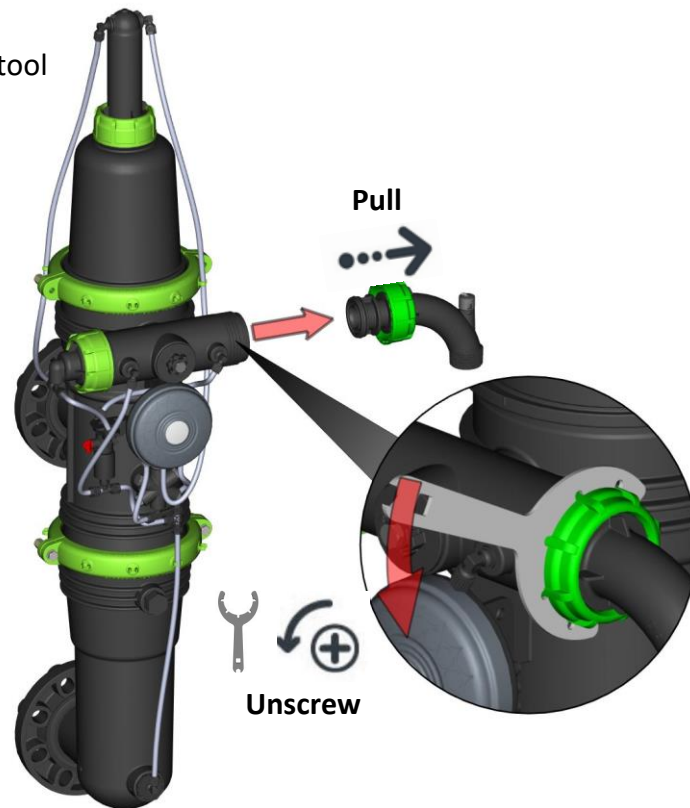

2. Disconnect the actuator valve
 - a. Disconnect the command tubes which are connected to the T-connector

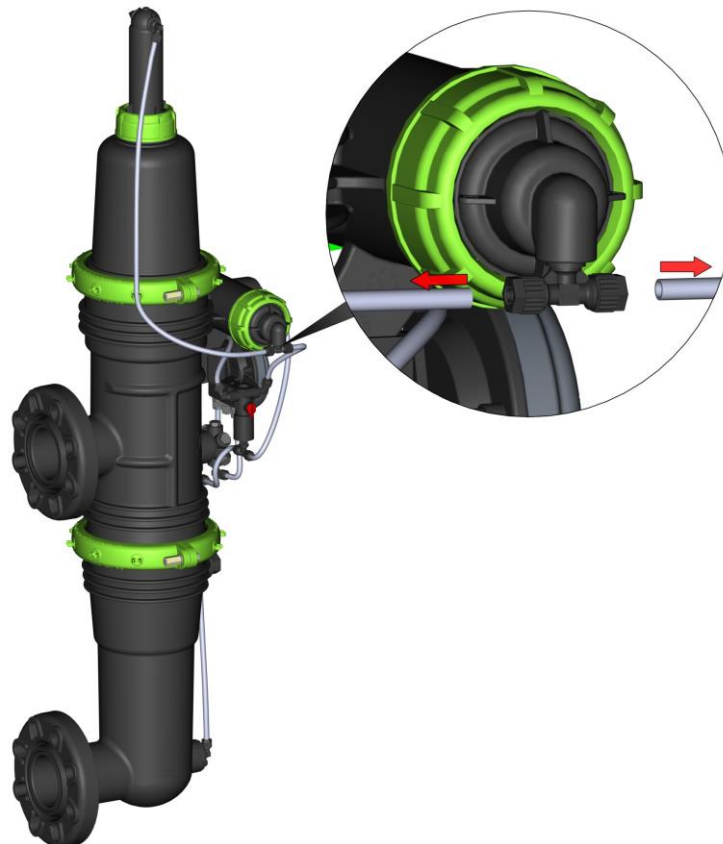

- b. Open the nut and pull out the actuator valve, using the Sigma multi-tool

Note: Loaded spring.

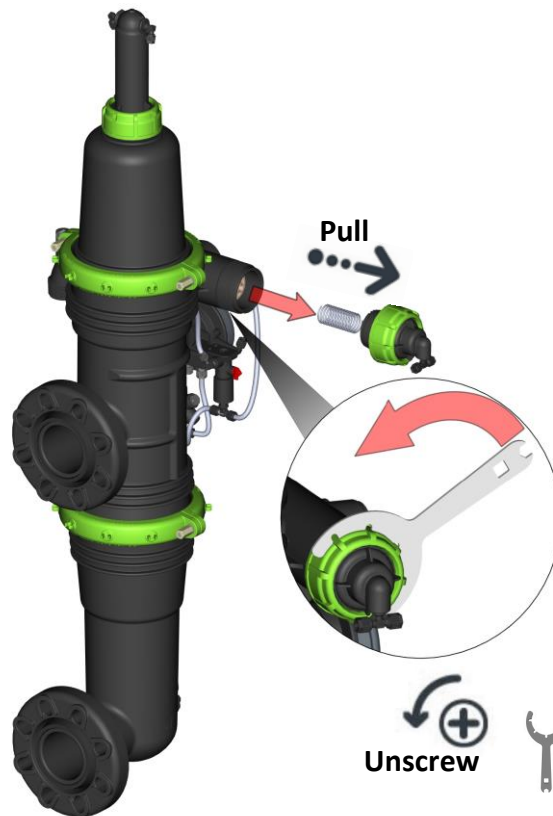

- c. Push out the actuator valve as shown below
d. Pull out the actuator valve

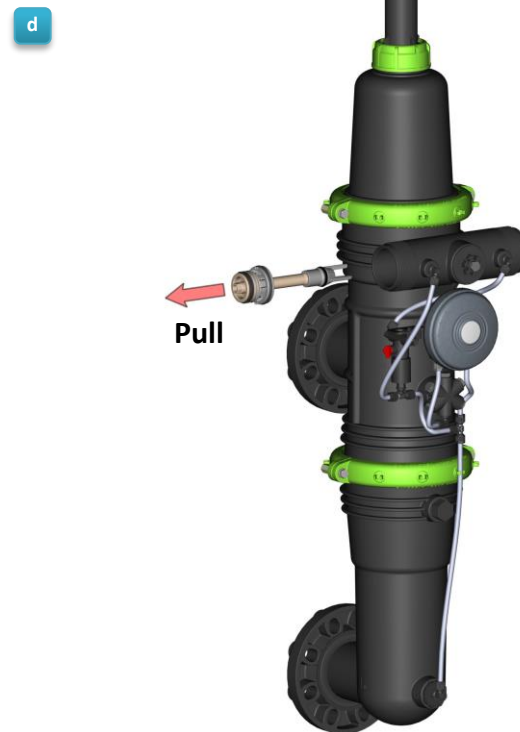
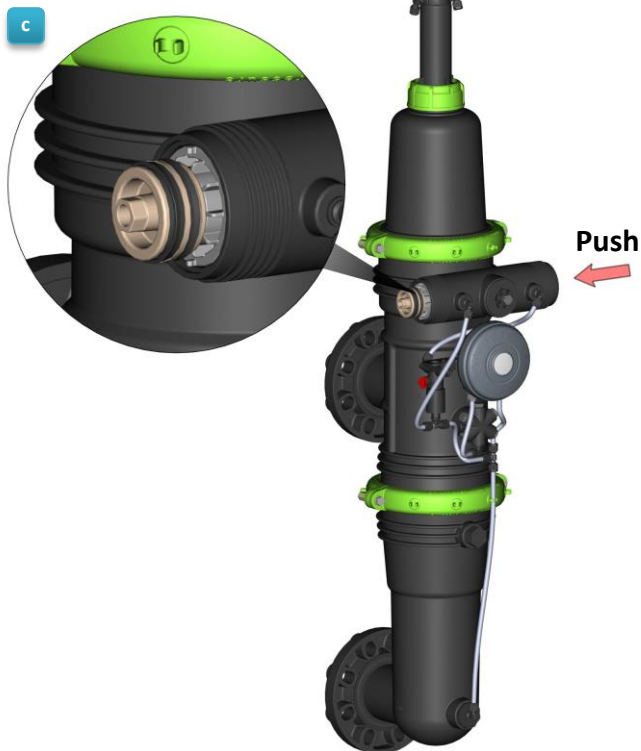

3. Before assembly:
- Make sure that all parts are undamaged
 - Replace dry or damaged gaskets and o-rings
 - Make sure that all parts are clean
 - Apply silicon grease on the o-rings (760190-000127 – tube of grease PG-21)

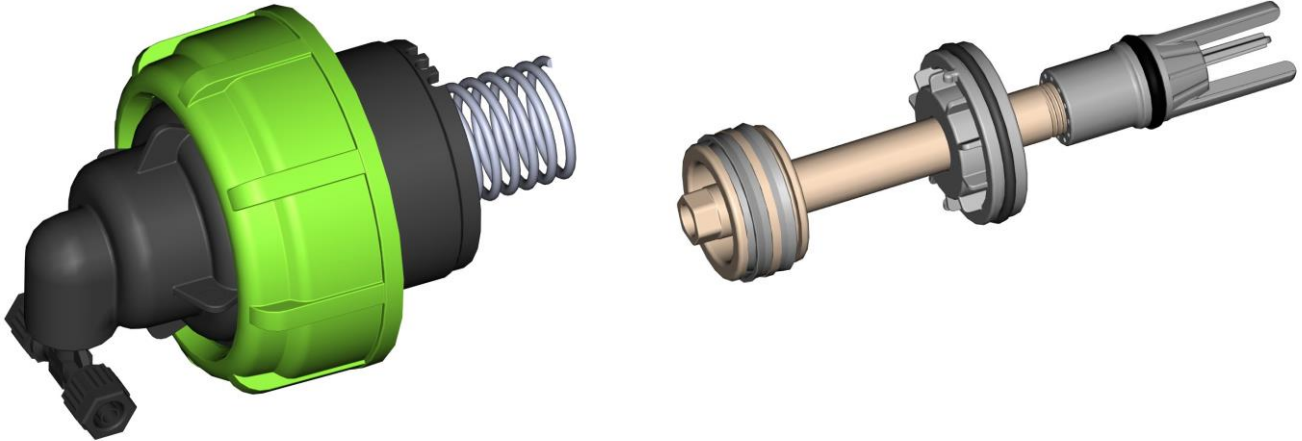

Actuator valve

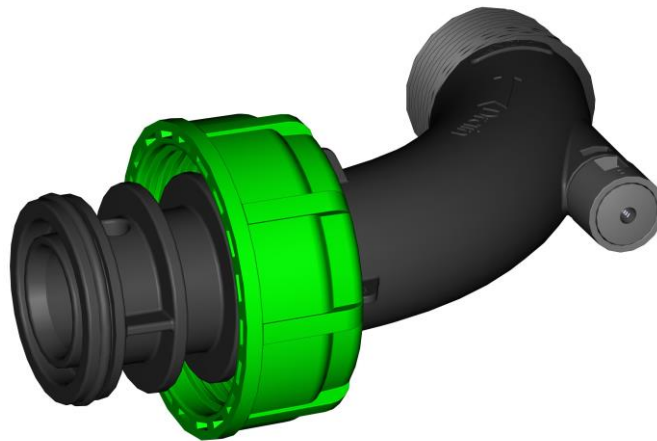

Drain pipe

Note: The drain pipe can be connected on either side of the filter, in case of side replacement remember to connect the command tubes accordingly

4. Reassemble the actuator valve

Note: Loaded spring

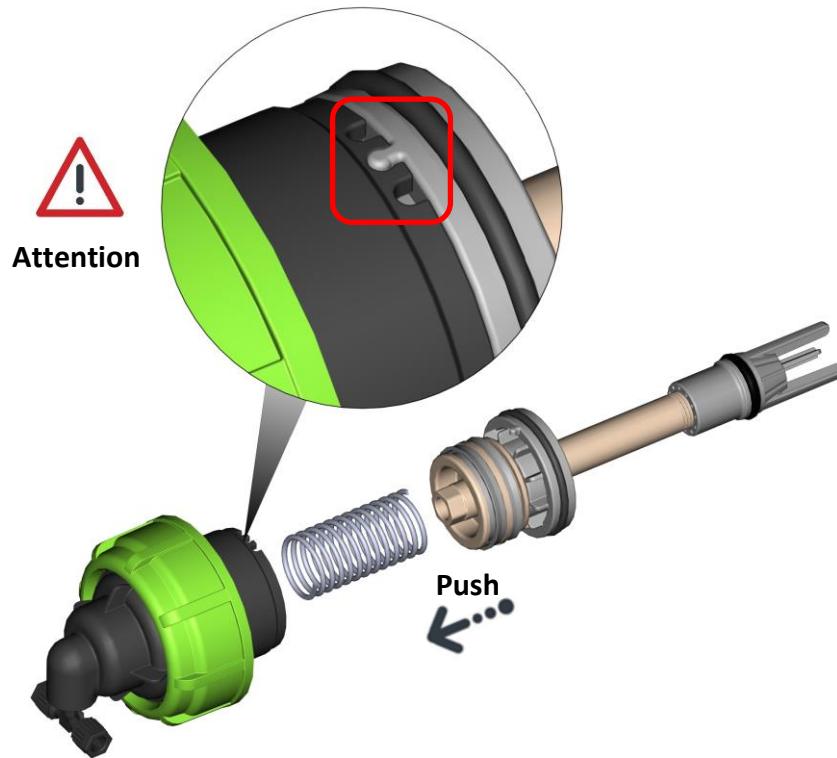

5. Connect the actuator valve and tighten the nut with the Sigma multi-tool

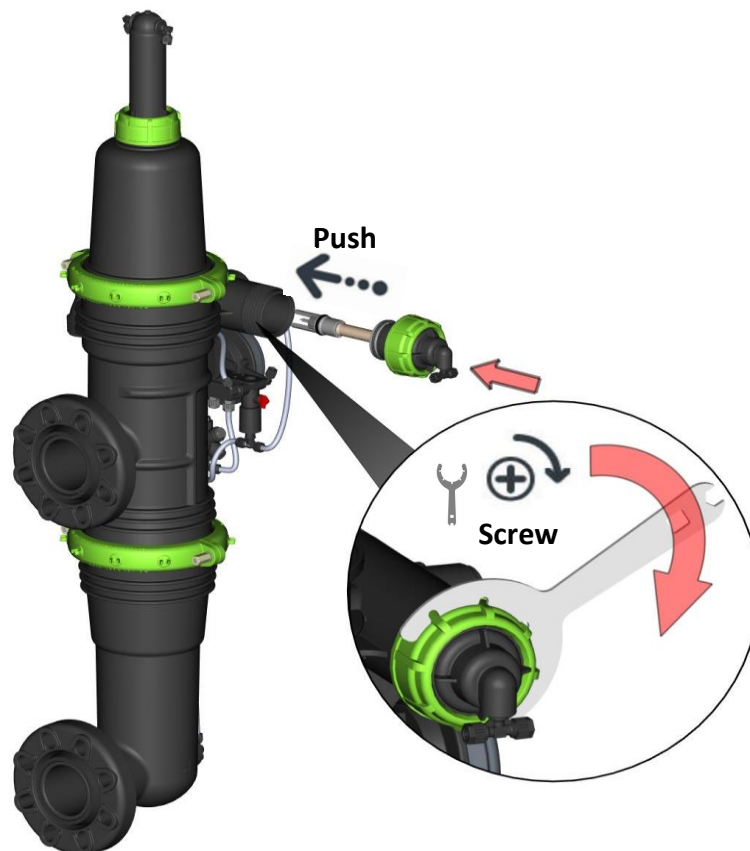

6. Connect the drain pipe and tighten the nut with the Sigma multi-tool

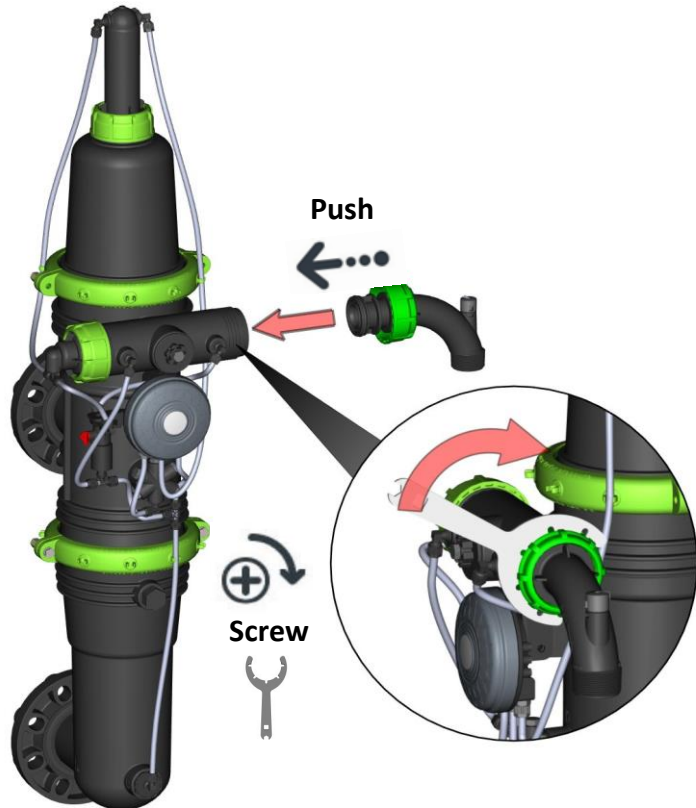

7. Connect the command tubes

Note: If the drain pipe and the actuator valve change sides remember to change the command tubes accordingly

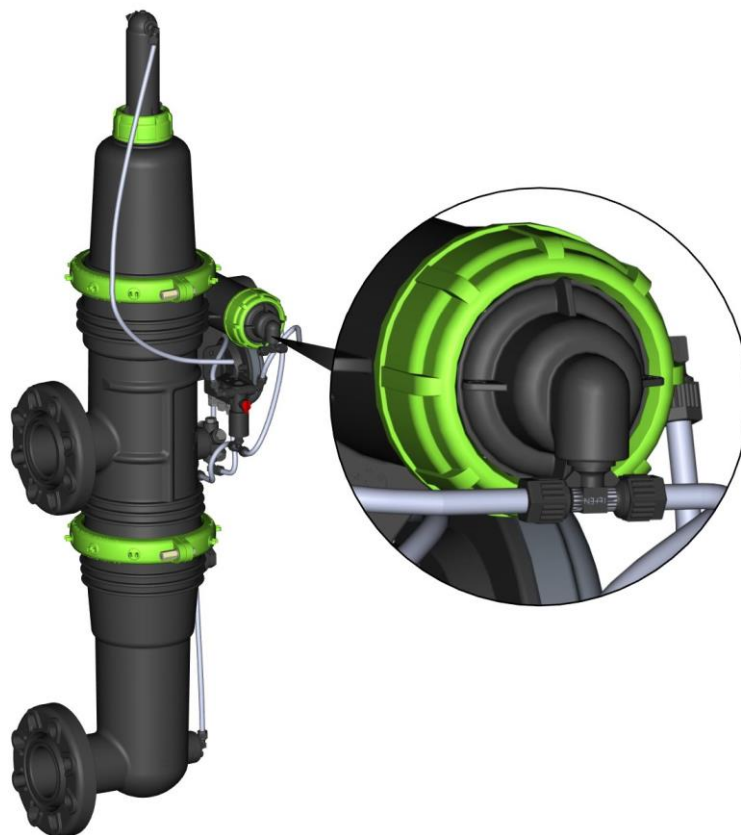

8. Cylinder disassembly:

- a. Disconnect the command pipes

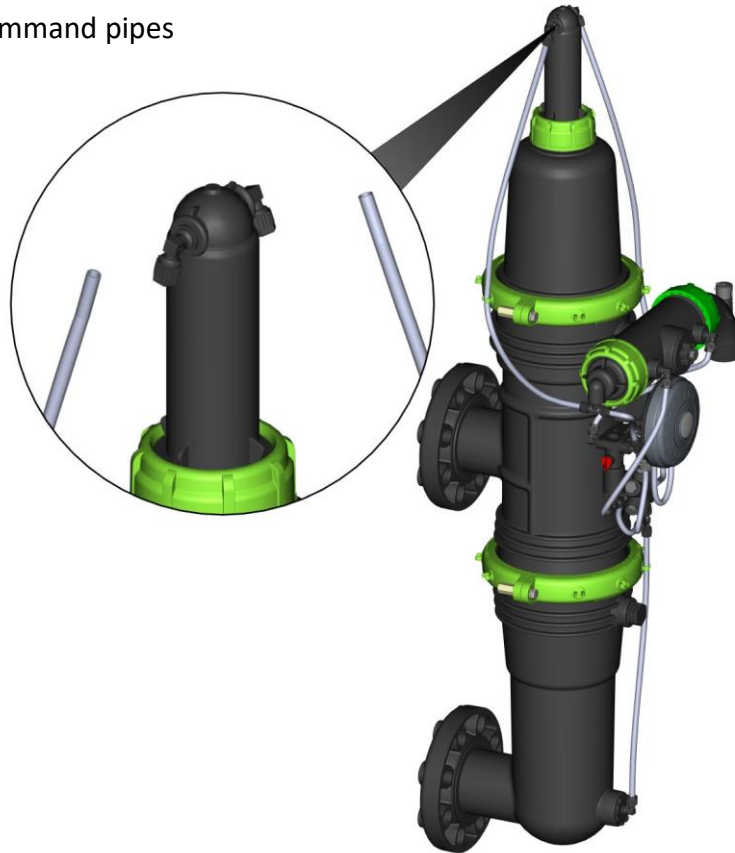

- b. Open the nut using the Sigma multi-tool

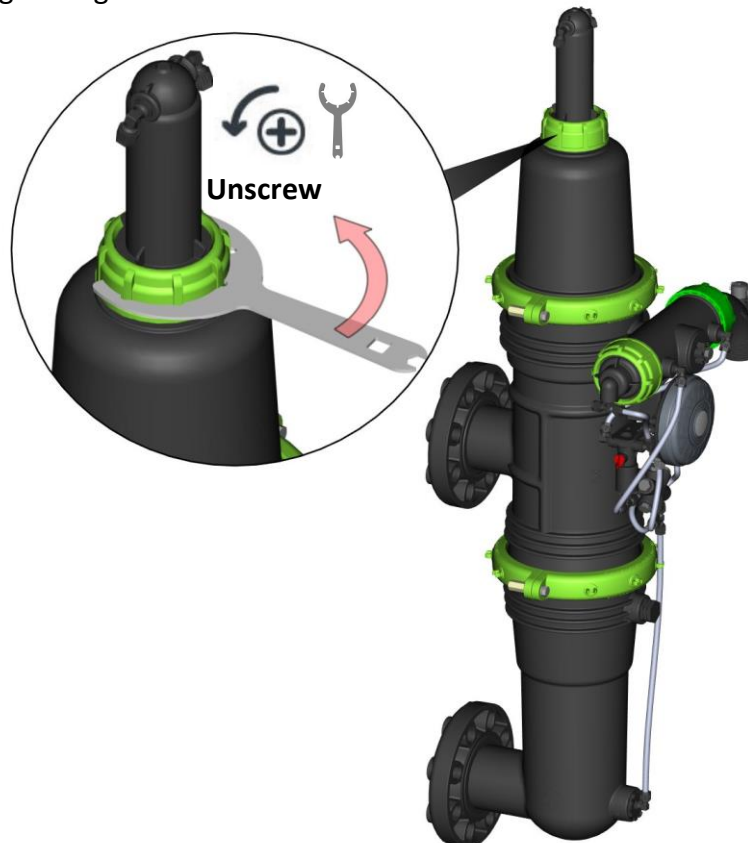

c. Pull out the cylinder



d. Disconnect the piston

e. Make sure that all parts below are clean and undamaged

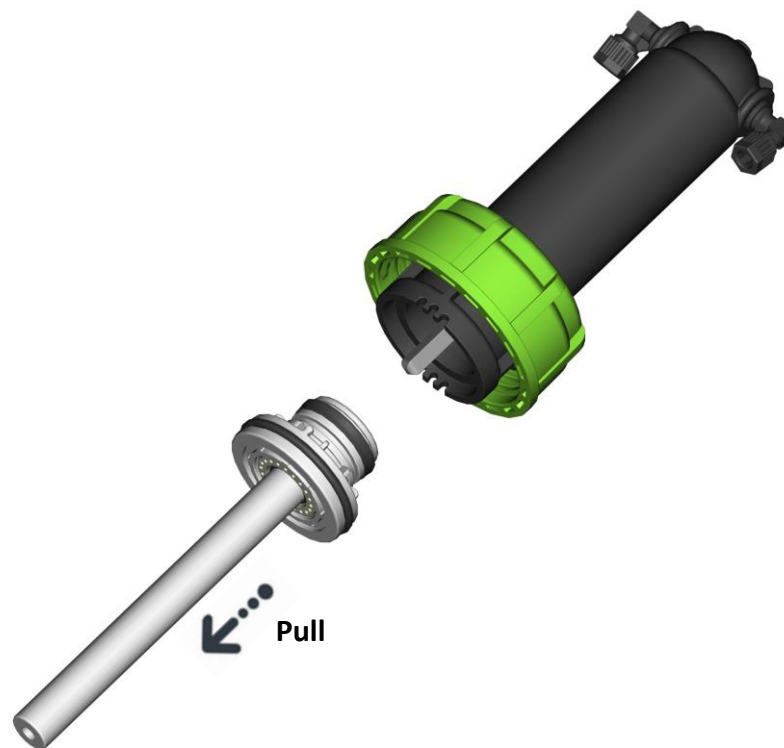

9. Cylinder assembly:

- a. Connect the piston

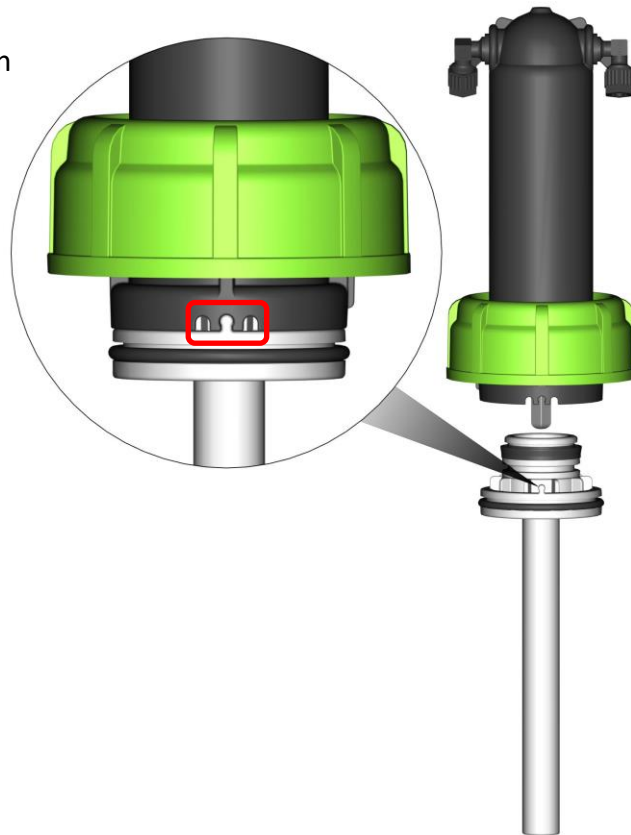

- b. Insert the cylinder assembly to the cover, ensuring that the key shaft was inserted in the right place

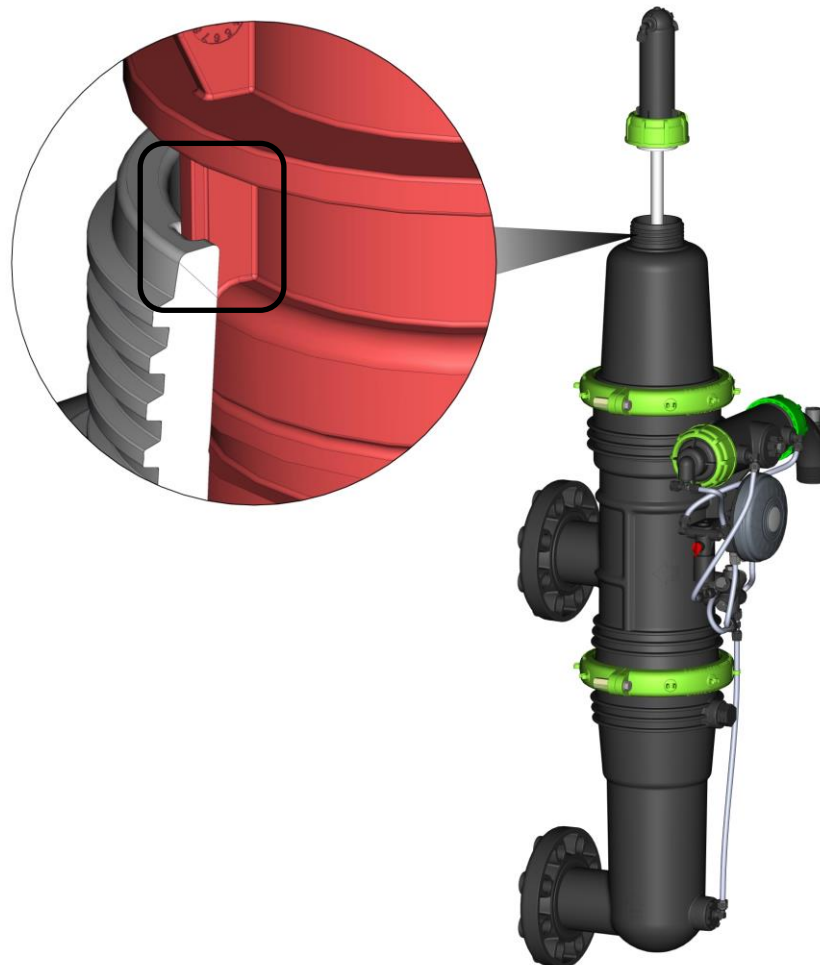

c. Tighten the nut using the Sigma multi-tool

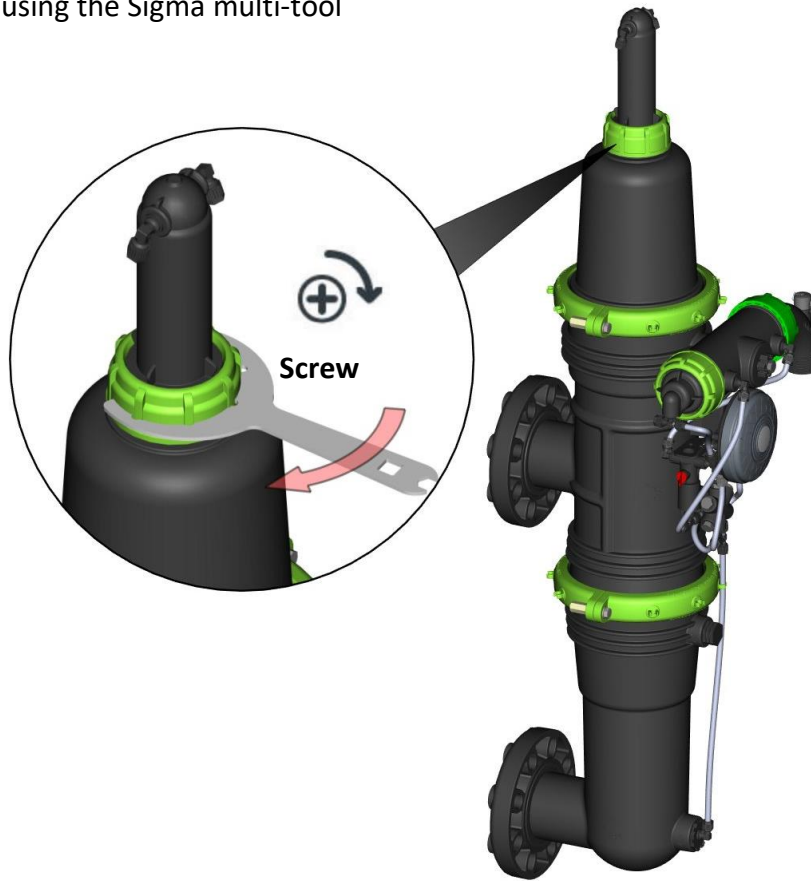

d. Connect the command tubes

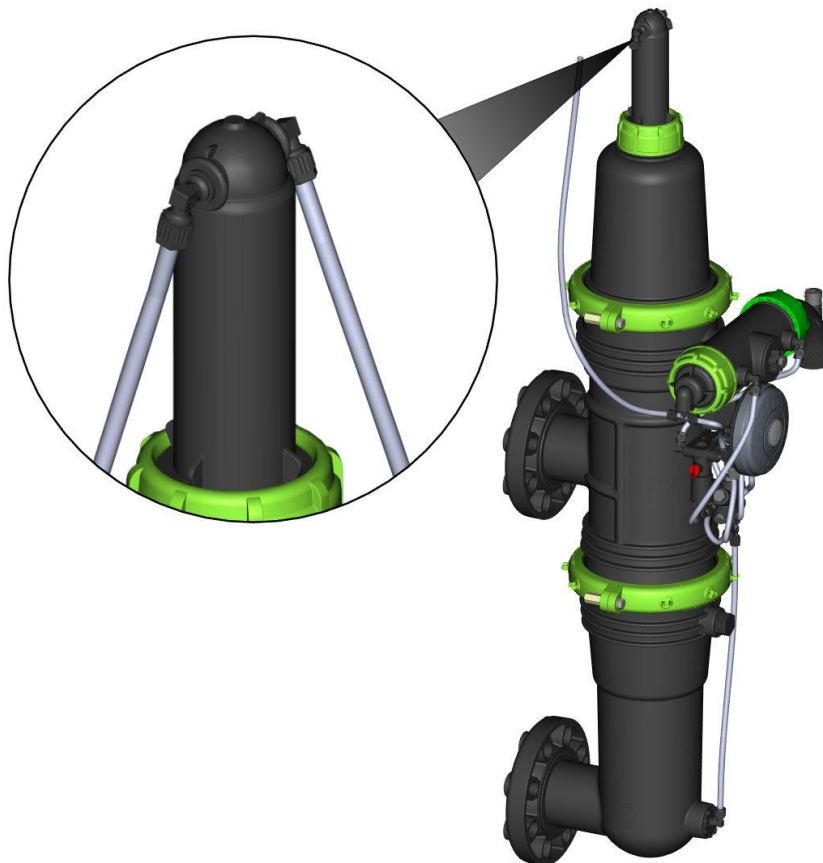

Bill of Materials – 2" On-line

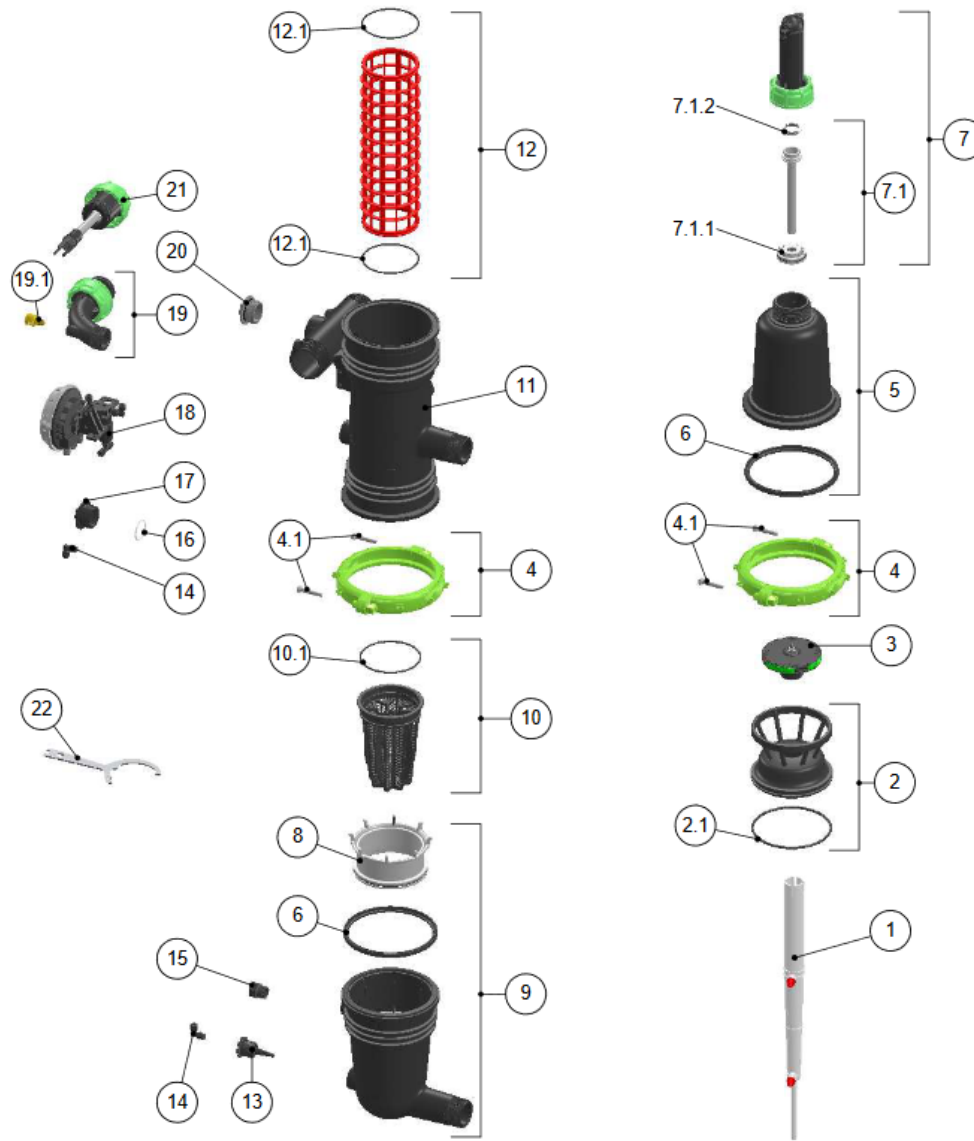

ITEM NO.	PART NUMBER	DESCRIPTION	QTY
1	700190-005106	SCANNER 375 ASSEMBLY W/STRAIGHT NOZZLE 8MM F/SIGMA 4"	1
2	700190-005252	SEPARATION PLATE ASSEMBLY W/ O-RING 2-361 EPDM	1
2.1	770102-000048	PARKER O-RING 2-361 EPDM 70 SHORE YELLOW DOT	1
3	700190-005150	TURBINE ASSEMBLY F/MINI AND PRO SIGMA	1
4	700190-005396	CLAMP ASSEMBLY FOR MINI SIGMA	2
4.1	700190-005413	SET BOLTS NUTS WASHERS FOR CLAMP MINI SIGMA	4
5	700190-005395	COVER ASSEMBLY F/MINI SIGMA W/HYDRAULIC SEAL	1
6	770104-000358	HYDRAULIC SEAL 2"-3" EPDM 70 SHORE SIGMA	2
7	700190-005154	ACTUATOR ASSEMBLY F/MINI SIGMA	1
7.1	700190-005161	ACTUATOR PISTON ASSEMBLY F/MINI SIGMA	1
7.1.1	700190-005153	SEAL HOLDER ASSEMBLY F/MINI SIGMA	1
7.1.2	770105-000010	U-CUP NBR OD38MM ID30MM H6.35MM 70SH	1
8	700190-005253	COARSE SCREEN ASSEMBLY 2" ADAPTOR W/ O-RING 2-255 EPDM	1
9	700190-005399	2" MINI SIGMA ON-LINE LOW BODY BSPT ASSEMBLY W/HYD SEAL	1
	700190-005400	MINI SIGMA LOWER BODY 2" ON-LINE NPT W/HYD SEAL	1
10	700190-005149	COARSE SCREEN ASSEMBLY FOR MINI SIGMA	1
10.1	770101-000198	MM O-RING SEAL ID117MM TH4MM EPDM 70 SHORE YELLOW DOT	1

ITEM NO.	PART NUMBER	DESCRIPTION	QTY
11	710101-001381	2" MINI SIGMA BODY BSPT RPA BLACK	1
	710101-001382	SIGMA BODY NPT RPA BLACK	
12	700101-001505	MOLDED WW 316L 130M SIGMA EPDM W/O-RINGS	1
12.1	770102-000384	PARKER O-RING 2-244 EPDM 70 SHORE YELLOW DOT	2
13	700190-000206	1"*1/4" BUSHING + SEAL	1
14	720501-000139	L-CONNECTOR 1/4"M X 8MM BSPT AC BLACK TEFEN	2
15	780101-000113	3/4" PLUG + 22.5*2 SEAL TAVLIT	1
16	770102-000287	PARKER O-RING 2-128 EPDM 70 SHORE YELLOW DOT	1
17	710101-001565	ADAPTOR 1"x1/4" PBT BLACK	1
18	700103-001749	ADI-P DC KIT PACKAGE	1
19	700190-005151	DRAIN PIPE ASSEMBLY 1.5" BSPT F/MINI SIGMA	1
	700190-005255	ASSEMBLY DRAIN PIPE 1.5" NPT FOR MINI SIGMA	
19.1	700190-005152	VACUUM BREAKER ASSEMBLY F/MINI SIGMA	1
20	700190-005254	1.5"-1/4" PLUG ASSEMBLY W/ O-RING 2-131 EPDM	1
21	700190-005241	VALVE ACTUATOR ASSEMBLY F/MINI SIGMA	1
22	760109-000472	WRENCH GALVANIZED FOR NUT MINI SIGMA	1

Bill of Materials – 2" Angle

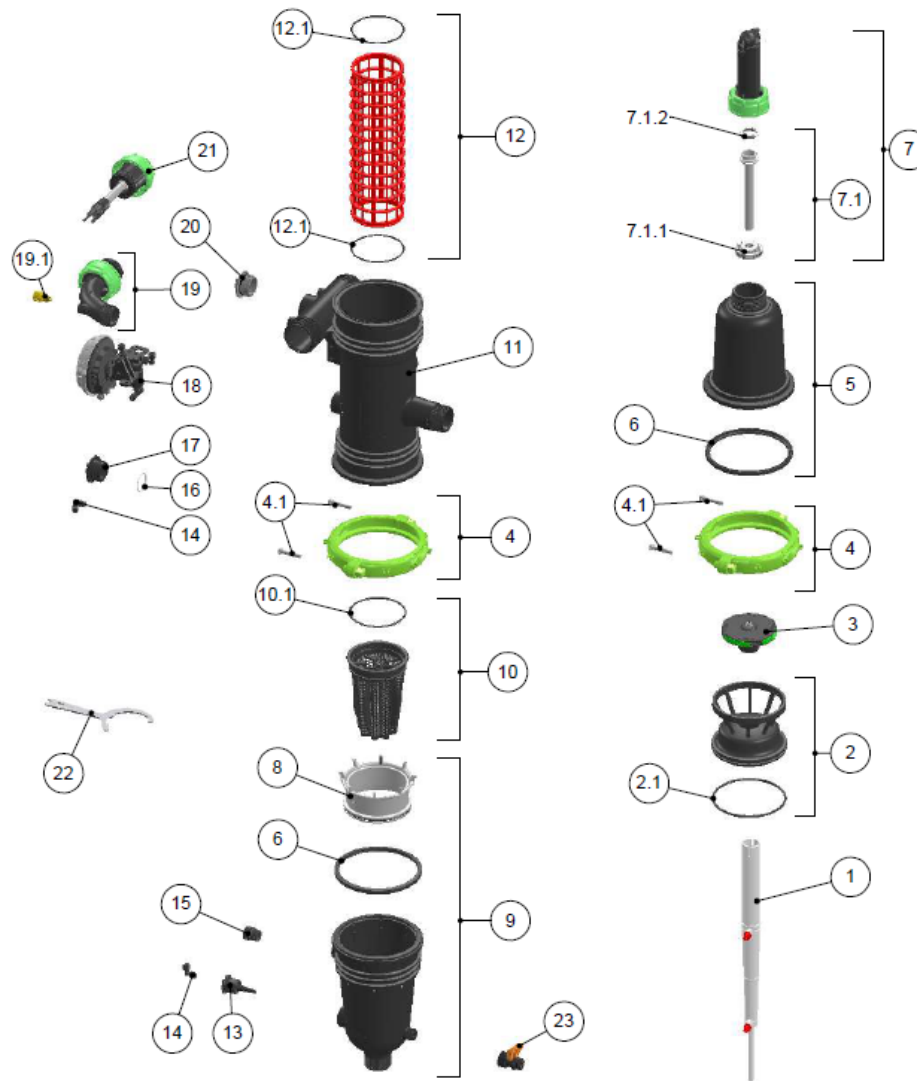

ITEM NO.	PART NUMBER	DESCRIPTION	QTY	ITEM NO.	PART NUMBER	DESCRIPTION	QTY
1	700190-005106	SCANNER 375 ASSEMBLY W/STRAIGHT NOZZLE 8MM F/SIGMA 4"	1	11	710101-001381	2" MINI SIGMA BODY BSPT RPA BLACK	1
2	700190-005252	SEPARATION PLATE ASSEMBLY W/ O-RING 2-361 EPDM	1		710101-001382	SIGMA BODY NPT RPA BLACK	1
2.1	770102-000048	PARKER -RING 2-361 EPDM 70 SHORE YELLOW DOT	1	12	700101-001505	MOLDED WW 316L 130M SIGMA EPDM W/O-RINGS	1
3	700190-005150	TURBINE ASSEMBLY F/MINI AND PRO SIGMA	1	12.1	770102-000384	PARKER O-RING 2-244 EPDM 70 SHORE YELLOW DOT	2
4	700190-005396	CLAMP ASSEMBLY FOR MINI SIGMA	2	13	700190-000206	1"X1/4" BUSHING + SEAL	1
4.1	700190-005413	SET BOLTS NUTS WASHERS FOR CLAMP MINI SIGMA	4	14	720501-000139	L-CONNECTOR 1/4"M X 8MM BSPT AC BLACK TEFEN	2
5	700190-005395	COVER ASSEMBLY F/MINI SIGMA W/HYDRAULIC SEAL	1	15	780101-000113	3/4" PLUG + 22.5*2 SEAL TAVLIT	1
6	770104-000358	HYDRAULIC SEAL 2"-3" EPDM 70 SHORE SIGMA	2	16	770102-000287	PARKER O-RING 2-128 EPDM 70 SHORE YELLOW DOT	1
7	700190-005154	ACTUATOR ASSEMBLY F/MINI SIGMA	1	17	710101-001565	ADAPTOR 1"X1/4" PBT BLACK	1
7.1	700190-005161	ACTUATOR PISTON ASSEMBLY F/MINI SIGMA	1	18	700103-001749	ADI-P DC KIT PACKAGE	1
7.1.1	700190-005153	SEAL HOLDER ASSEMBLY F/MINI SIGMA	1		700190-005151	DRAIN PIPE ASSEMBLY 1.5" BSPT F/MINI SIGMA	1
7.1.2	770105-000010	U-CUP NBR OD38MM ID30MM H6.35MM 70 SHORE	1		700190-005255	ASSEMBLY DRAIN PIPE 1.5" NPT FOR MINI SIGMA	1
8	700190-005253	COARSE SCREEN ASSEMBLY 2" ADAPTOR W/ O-RING 2-255 EPDM	1	19.1	700190-005152	VACUUM BREAKER ASSEMBLY F/MINI SIGMA	1
	700190-005397	2" MINI SIGMA ANGEL LOW BODY BSPT ASSEMBLY W/HYD SEAL	1	20	700190-005254	1.5"-1/4" PLUG ASSEMBLY W/ O-RING 2-131 EPDM	1
9	700190-005398	MINI SIGMA LOWER BODY 2" ANGLE NPT W/HYD. SEAL	1	21	700190-005241	VALVE ACTUATOR ASSEMBLY F/MINI SIGMA	1
10	700190-005149	COARSE SCREEN ASSEMBLY FOR MINI SIGMA	1	22	760109-000472	WRENCH GALVANIZED FOR NUT MINI SIGMA	1
10.1	770101-000198	MM O-RING SEAL ID117MM TH4MM EPDM 70 SHORE YELLOW DOT	1	23	300005-000006	BALL VALVE AC 3/4" 10 BAR BLACK FOR 2"T	1

Bill of Materials – 3" On-line

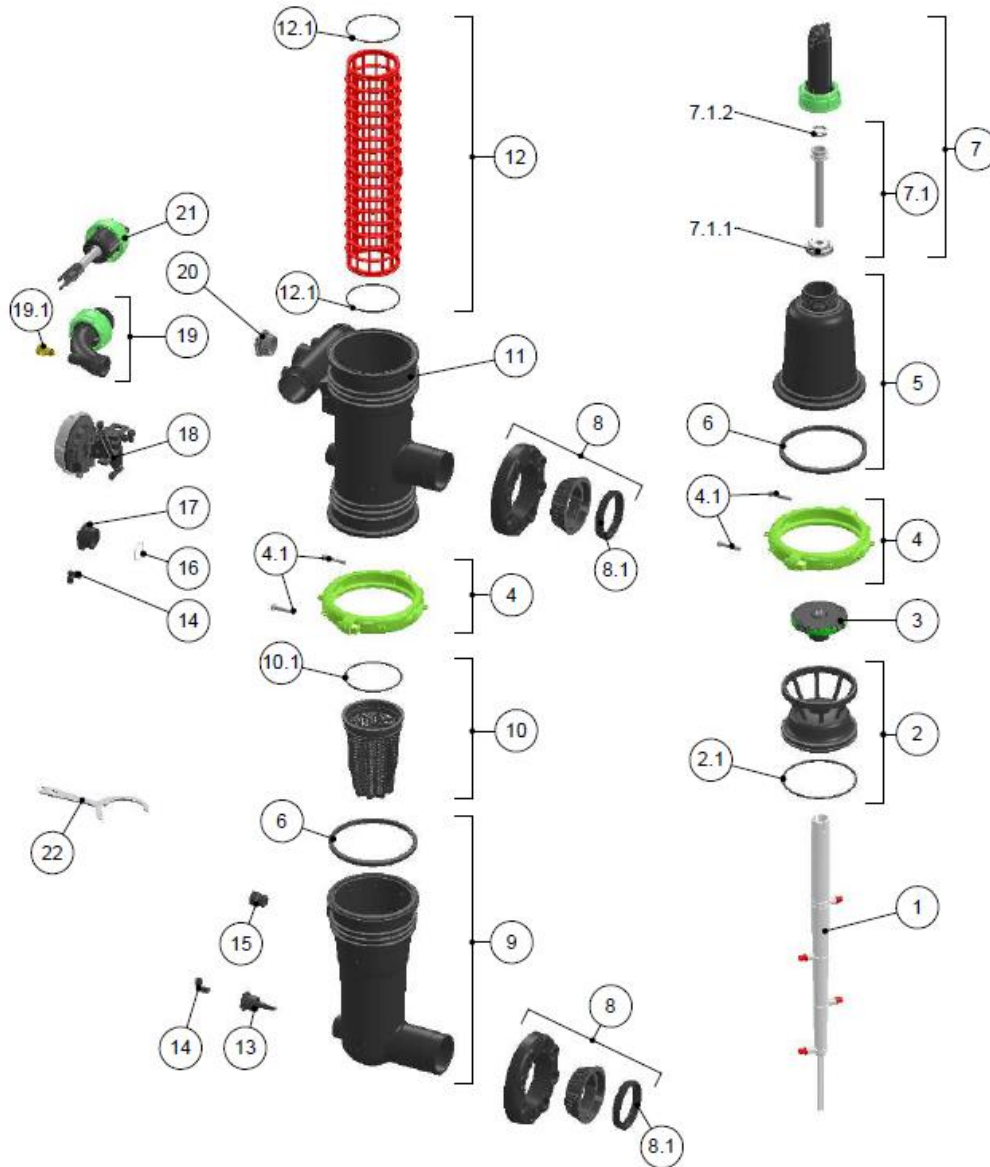

ITEM NO.	PART NUMBER	DESCRIPTION	QTY	ITEM NO.	PART NUMBER	DESCRIPTION	QTY
1	700190-005105	SCANNER 500 ASSEMBLY W/STRAIGHT NOZZLE 8MM F/SIGMA 6"/8"	1	10.1	770101-000198	MM O-RING SEAL ID117MM TH4MM EPDM 70 SHORE YELLOW DOT	1
2	700190-005252	SEPARATION PLATE ASSEMBLY W/ O-RING 2-361 EPDM	1	11	710101-001383	3" MINI SIGMA BODY VIC RPA BLACK	1
2.1	770102-000048	PARKER O-RING 2-361 EPDM 70 SHORE YELLOW DOT	1	12	700101-002042	MOLDED WW SCREEN S/ST316L 130 MICRON FOR 3" SIGMA EPDM SEALS	1
3	700190-005150	TURBINE ASSEMBLY F/MINI AND PRO SIGMA	1	12.1	770102-000384	PARKER O-RING 2-244 EPDM 70 SHORE YELLOW DOT	2
4	700190-005396	CLAMP ASSEMBLY FOR MINI SIGMA	2	13	700190-000206	1"*1/4" BUSHING + SEAL	1
4.1	700190-005413	SET BOLTS NUTS WASHERS FOR CLAMP MINI SIGMA	1	14	720501-000139	L-CONNECTOR 1/4"M X 8MM BSPT AC BLACK TEFEN	2
5	700190-005395	COVER ASSEMBLY F/MINI SIGMA W/HYDRAULIC SEAL	1	15	780101-000113	3/4" PLUG + 22.5*2 SEAL TAVLIT	1
6	770104-000358	HYDRAULIC SEAL 2"-3" EPDM 70 SHORE SIGMA	2	16	770102-000287	PARKER O-RING 2-128 EPDM 70 SHORE YELLOW DOT	1
7	700190-005154	ACTUATOR ASSEMBLY F/MINI SIGMA	1	17	710101-001565	ADAPTOR 1"X1/4" PBT BLACK	1
7.1	700190-005161	ACTUATOR PISTON ASSEMBLY F/MINI SIGMA	1	18	700103-001749	ADI-P DC KIT PACKAGE	1
7.1.1	700190-005153	SEAL HOLDER ASSEMBLY F/MINI SIGMA	1	19	700190-005151	DRAIN PIPE ASSEMBLY 1.5" BSPT F/MINI SIGMA	1
7.1.2	770105-000010	U-CUP NBR OD38MM ID30MM H6.35MM 70SH	1	19.1	700190-005152	VACUUM BREAKER ASSEMBLY F/MINI SIGMA	1
8	700190-000223	3" AKF UNIVERSAL FLANG	2	20	700190-005254	1.5"-1/4" PLUG ASSEMBLY W/ O-RING 2-131 EPDM	1
8.1	770104-000034	GASKET EPDM 65 SHORE FOR QUICK FLANGE	2	21	700190-005241	VALVE ACTUATOR ASSEMBLY F/MINI SIGMA	1
9	700190-005402	3" MINI SIGMA ON-LINE LOW BODY VIC ASSEMBLY W/HYD SEAL	1	22	760109-000472	WRENCH GALVANIZED FOR NUT MINI SIGMA	1
10	700190-005149	COARSE SCREEN ASSEMBLY FOR MINI SIGMA	1				

Bill of Materials – 3" Angle

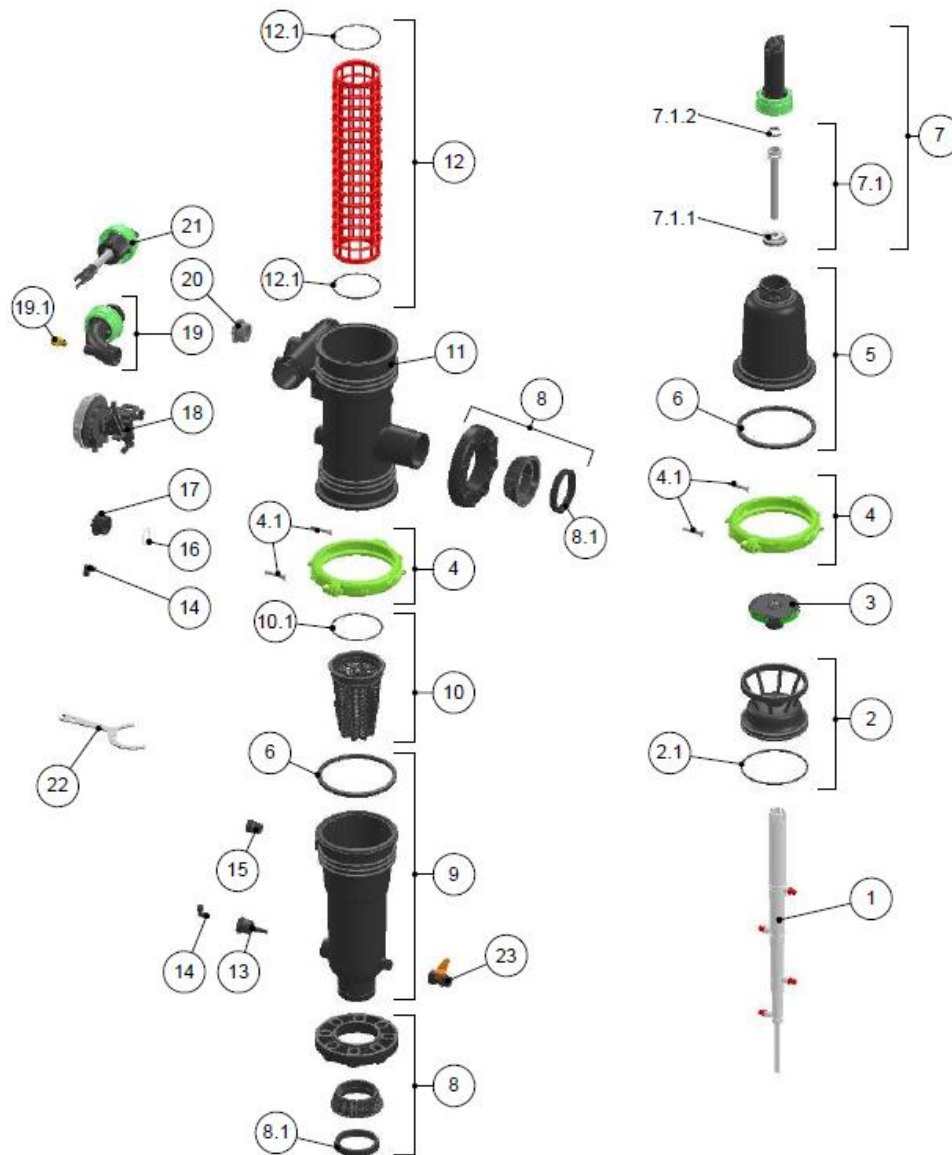

ITEM NO.	PART NUMBER	DESCRIPTION	QTY	ITEM NO.	PART NUMBER	DESCRIPTION	QTY
1	700190-005105	SCANNER 500 ASSEMBLY W/STRAIGHT NOZZLE 8MM F/SIGMA 6"/8"	1	10.1	770101-000198	MM O-RING SEAL ID117MM TH4MM EPDM 70 SHORE YELLOW DOT	1
2	700190-005252	SEPARATION PLATE ASSEMBLY W/ O-RING 2-361 EPDM	1	11	710101-001383	3" MINI SIGMA BODY VIC RPA BLACK	1
2.1	770102-000048	PARKER O-RING 2-361 EPDM 70SHORE YELLOW D	1	12	700101-002042	MOLDED WW SCREEN S/ST316L 130MIC 3" SIGMA EPDM SEALS	1
3	700190-005150	TURBINE ASSEMBLY F/MINI AND PRO SIGMA	1	12.1	770102-000384	PARKER O-RING 2-244 EPDM 70 SHORE YELLOW DOT	2
4	700190-005396	CLAMP ASSEMBLY FOR MINI SIGMA	2	13	700190-000206	1"*1/4" BUSHING + SEAL	1
4.1	700190-005413	SET BOLTS NUTS WASHERS FOR CLAMP MINI SIGMA	4	14	720501-000139	L-CONNECTOR 1/4"M X8MM BSPT AC BLACK TEFEN	2
5	700190-005395	COVER ASSEMBLY F/MINI SIGMA W/HYDRAULIC SEAL	1	15	780101-000113	3/4" PLUG + 22.5*2 SEAL TAVLIT	1
6	770104-000358	HYDRAULIC SEAL 2"-3" EPDM 70 SHORE SIGMA	2	16	770102-000287	PARKER O-RING 2-128 EPDM 70 SHORE YELLOW DOT	1
7	700190-005154	ACTUATOR ASSEMBLY F/MINI SIGMA	1	17	710101-001565	ADAPTOR 1"x1/4" PBT BLACK	1
7.1	700190-005161	ACTUATOR PISTON ASSEMBLY F/MINI SIGMA	1	18	700103-001749	ADI-P DC KIT PACKAGE	1
7.1.1	700190-005153	SEAL HOLDER ASSEMBLY F/MINI SIGMA	1	19	700190-005151	DRAIN PIPE ASSEMBLY 1.5" BSPT F/MINI SIGMA	1
7.1.2	770105-000010	U-CUP NBR OD38MM ID30MM H6.35MM 70SH	1	19.1	700190-005152	VACUUM BREAKER ASSEMBLY F/MINI SIGMA	1
8	700190-000223	3" AKF UNIVERSAL FLANGE	2	20	700190-005254	1.5"-1/4" PLUG ASSEMBLY W/ O-RING 2-131 EPDM	1
8.1	770104-000034	GASKET EPDM 65 SHORE FOR QUICK FLANGE	2	21	700190-005241	VALVE ACTUATOR ASSEMBLY F/MINI SIGMA	1
9	700190-005401	3" MINI SIGMA ANGEL LOW BODY VIC ASSEMBLY W/HYD SEAL	1	22	760109-000472	WRENCH GALVANIZED FOR NUT MINI SIGMA	1
10	700190-005149	COARSE SCREEN ASSEMBLY FOR MINI SIGMA	1	23	300005-000006	BALL VALVE AC 3/4" 10 BAR BLACK FOR 2"T	1

Bill of Materials – 4" On-line

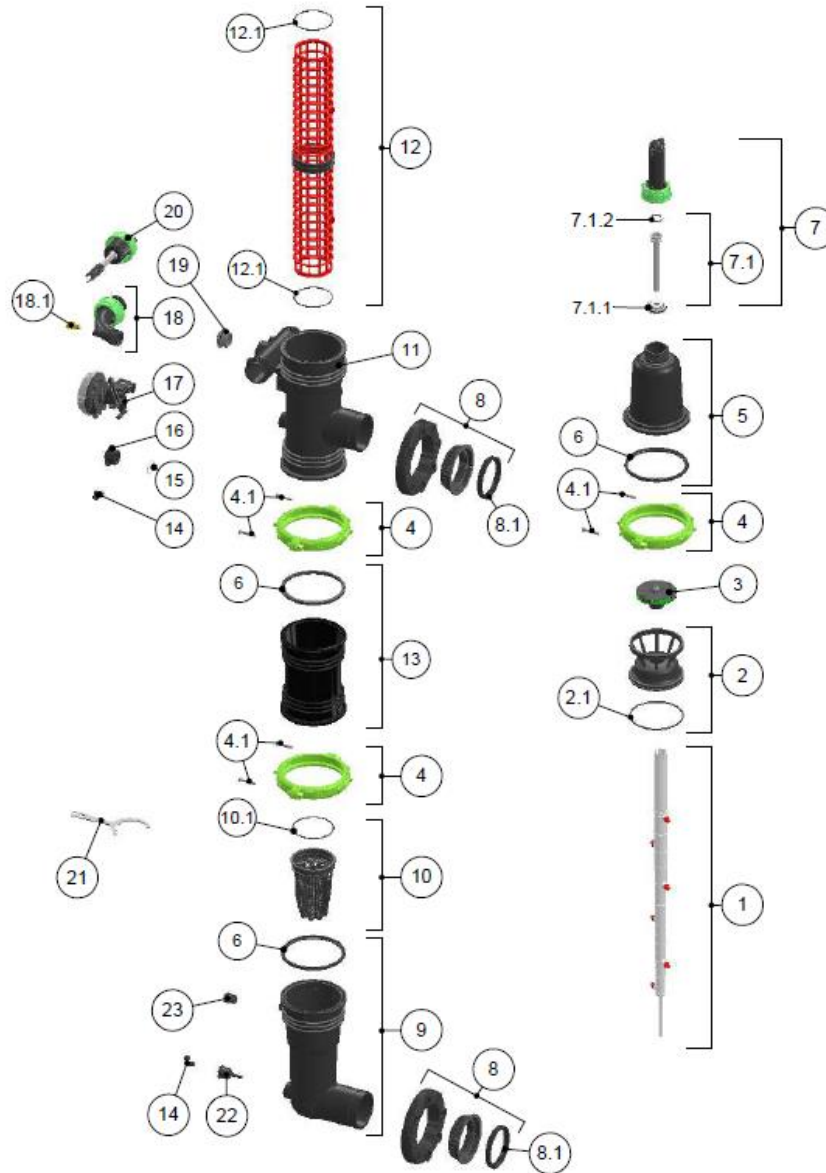

ITEM NO.	PART NUMBER	DESCRIPTION	QTY	ITEM NO.	PART NUMBER	DESCRIPTION	QTY
1	700190-005532	SCANNER 754 ASSEMBLY W/STRAIGHT NOZZLE 8MM F/SIGMA 4"	1	10.1	770101-000198	MM O-RING SEAL ID117MM TH4MM EPDM 70 SHORE YELLOW DOT	1
2	700190-005252	SEPARATION PLATE ASSEMBLY W/ O-RING 2-361 EPDM	1	11	710101-001384	4" MINI SIGMA BODY VIC RPA BLACK	1
2.1	770102-000048	PARKER O-RING 2-361 EPDM 70 SHORE YELLOW DOT	1	12	700101-002142	MOLDED WW SCREEN S/ST316L 2400SQ.CM 130 MICRON	1
3	700190-005150	TURBINE ASSEMBLY F/MINI AND PRO SIGMA	1	12.1	770102-000384	PARKER O-RING 2-244 EPDM 70 SHORE YELLOW DOT	2
4	700190-005396	CLAMP ASSEMBLY FOR MINI SIGMA	3	13	700190-005533	SPACER ASSEMBLY W/HYD SEAL F/4" MINI SIGMA	1
4.1	700190-005413	SET BOLTS NUTS WASHERS FOR CLAMP MINI SIGMA	1	14	720501-000139	L-CONNECTOR 1/4"M X8MM BSPT AC BLK TEFEN	2
5	700190-005395	COVER ASSEMBLY F/MINI SIGMA W/HYDRAULIC SEAL	1	15	770102-000287	PARKER O-RING 2-128 EPDM 70 SHORE YELLOW DOT	1
6	770104-000358	HYDRAULIC SEAL 2"-3" EPDM 70 SHORE SIGMA	3	16	710101-001565	ADAPTOR 1"x1/4" PBT BLACK	1
7	700190-005154	ACTUATOR ASSEMBLY F/MINI SIGMA	1	17	700103-001749	ADI-P DC KIT PACKAGE	1
7.1	700190-005161	ACTUATOR PISTON ASSEMBLY F/MINI SIGMA	1	18	700190-005151	DRAIN PIPE ASSEMBLY 1.5" BSPT F/MINI SIGMA	1
7.1.1	700190-005153	SEAL HOLDER ASSEMBLY F/MINI SIGMA	1	18.1	700190-005152	VACUUM BREAKER ASSEMBLY F/MINI SIGMA	1
7.1.2	770105-000010	U-CUP NBR OD38MM ID30MM H6.35MM 70SH	1	19	700190-005254	1.5"-1/4" PLUG ASSEMBLY W/ O-RING 2-131 EPDM	1
8	700190-000227	4" ARKAL SNAP FLANGE ASSEMBLY	2	20	700190-005241	VALVE ACTUATOR ASSEMBLY F/MINI SIGMA	1
8.1	770104-000253	GASKET 4" EPDM 70 SHORE QUICK FLANGE	2	21	760109-000472	WRENCH GALVANIZED FOR NUT MINI SIGMA	1
9	700190-005404	4" MINI SIGMA ON-LINE LOW BODY VIC ASSEMBLY W/HYD SEAL	1	22	700190-000206	1"*1/4" BUSHING + SEAL	1
10	700190-005149	COARSE SCREEN ASSEMBLY FOR MINI SIGMA	1	23	780101-000113	3/4" PLUG + 22.5*2 SEAL TAVLIT	1

Bill of Materials – 4" Angle

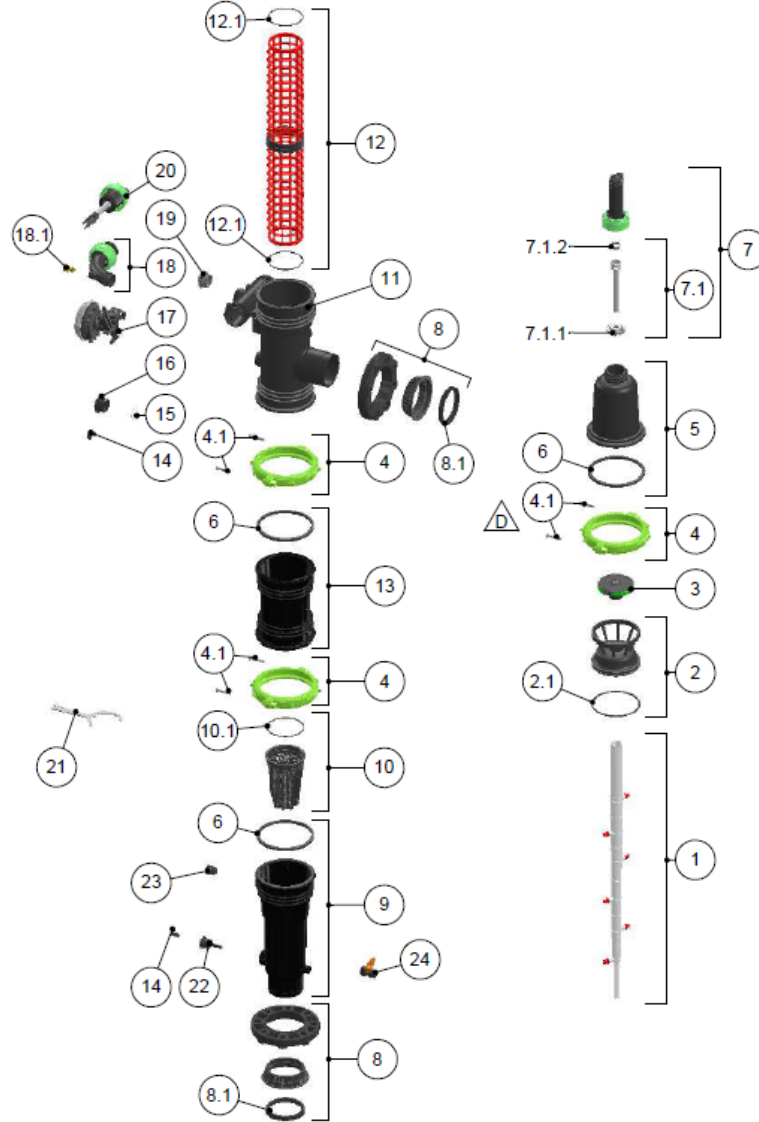

ITEM NO.	PART NUMBER	DESCRIPTION	QTY
1	700190-005532	SCANNER 754 ASSEMBLY W/STRAIGHT NOZZLE 8MM F/SIGMA 4"	1
2	700190-005252	SEPARATION PLATE ASSEMBLY W/ O-RING 2-361 EPDM	1
2.1	770102-000048	PARKER O-RING 2-361 EPDM 70SHORE YELLOW DOT	1
3	700190-005150	TURBINE ASSEMBLY F/MINI AND PRO SIGMA	1
4	700190-005396	CLAMP ASSEMBLY FOR MINI SIGMA	2
4.1	700190-005413	SET BOLTS NUTS WASHERS FOR CLAMP MINI SIGMA	4
5	700190-005395	COVER ASSEMBLY F/MINI SIGMA W/HYDRAULIC SEAL	1
6	770104-000358	HYDRAULIC SEAL 2"-3" EPDM 70 SHORE SIGMA	2
7	700190-005154	ACTUATOR ASSEMBLY F/MINI SIGMA	1
7.1	700190-005161	ACTUATOR PISTON ASSEMBLY F/MINI SIGMA	1
7.1.1	700190-005153	SEAL HOLDER ASSEMBLY F/MINI SIGMA	1
7.1.2	770105-000010	U-CUP NBR OD38MM ID30MM H6.35MM 70SH	1
8	700190-000227	4" ARKAL SNAP FLANGE ASSEMBLY	2
8.1	770104-000253	GASKET 4" EPDM 70 SHORE QUICK FLANGE	2
9	700190-005403	4" MINI SIGMA ANGLE LOW BODY VIC ASSEMBLY W/HYD SEAL	1
10	700190-005149	COARSE SCREEN ASSEMBLY FOR MINI SIGMA	1
10.1	770101-000198	MM O-RING SEAL ID117MM TH4MM EPDM 70 SHORE YELLOW DOT	1





ITEM NO.	PART NUMBER	DESCRIPTION	QTY
11	710101-001384	4" MINI SIGMA BODY VIC RPA BLACK	1
12	700101-002142	MOLDED WEAVEWIRE SCREEN S/ST316L 2400SQ.CM 130MIC MINI SIGMA	1
12.1	770102-000384	PARKER O-RING 2-244 EPDM 70 SHORE YELLOW DOT	2
13	700190-005533	ASSEMBLY MINI SIGMA SPACER W/HYD SEAL	1
14	720501-000139	L-CONNECTOR 1/4"M X8MM BSPT AC BLK TEFEN	2
15	770102-000287	PARKER O-RING 2-128 EPDM 70 SHORE YELLOW DOT	1
16	710101-001565	ADAPTOR 1"x1/4" PBT BLACK	1
17	700103-001749	ADI-P DC KIT PACKAGE	1
18	700190-005151	DRAIN PIPE ASSEMBLY 1.5" BSPT F/MINI SIGMA	1
18.1	700190-005152	VACUUM BREAKER ASSEMBLY F/MINI SIGMA	1
19	700190-005254	1.5"-1/4" PLUG ASSEMBLY W/ O-RING 2-131 EPDM	1
20	700190-005241	VALVE ACTUATOR ASSEMBLY F/MINI SIGMA	1
21	760109-000472	WRENCH GALVANIZED FOR NUT MINI SIGMA	1
22	700190-000206	1"*1/4" BUSHING + SEAL	1
23	780101-000113	3/4" PLUG+22.5*2 SEAL TAVLIT	1
24	300005-000006	BALL VALVE AC 3/4" 10 BAR BLACK FOR 2" T	1

Control Schematic

LEGEND :

SV - SOLENOID VALVE 12v DC LATCH
 VB - VACUUM BREAKER

SYMBOLS :

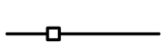
COMMAND		8 mm
HP		8 mm
LP		8 mm
VENT		8 mm
ELECTRIC		

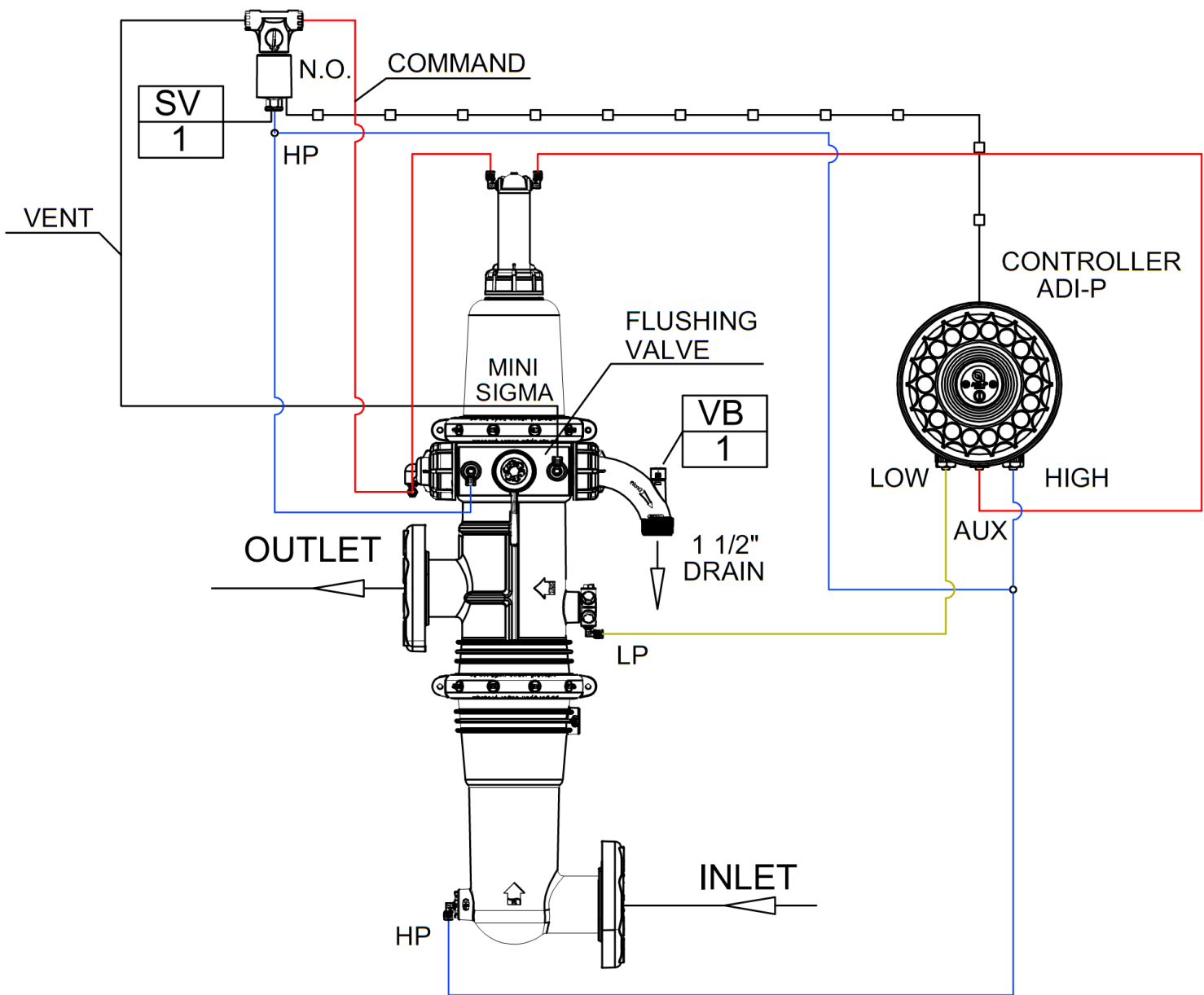

Troubleshooting

No	Symptom	Possible Causes	Required Action
1	High or elevated differential pressure between upstream and downstream	Coarse or fine screen is totally clogged	<ol style="list-style-type: none"> Perform automatic flushing <ol style="list-style-type: none"> Close the downstream valve Start a manual flushing cycle using the flushing controller Verify that the downstream pressure is equal or slightly lower than the upstream pressure If symptom continues and the filter remains clogged, stop the operation and manually clean the fine screen Perform manual cleaning <ol style="list-style-type: none"> Extract the coarse screen and fine screen. Clean manually with a high pressure wash before returning to regular operation. Please refer to the filter disassembly instructions on page 21 Verify that the downstream pressure is equal to, or slightly lower than the upstream pressure.
2	System flow-rate seems to be lower than usual	Coarse screen is clogged	<p>Manually clean the coarse screen:</p> <ol style="list-style-type: none"> Dismantle the coarse screens. Please refer to the filter disassembly instructions on page 21 Return to regular operation and check the filter's performance
3	Frequent, excessive flush cycles	Water quality has changed	Check the source water quality for poor quality conditions (e.g. flood/heavy rain/works upstream of intake/new dam, etc.)
		Controller flush duration set point too low (electronic control)	Reset "Flush Duration" set point to 10 seconds
4	The filter doesn't flush automatically (electronic controller)	Controller batteries are dead or power supply is isolated	Replace the controller's batteries or check the power supply (Refer to the ADI-P mobile app to check battery status before replacing)
		The solenoid is set in "Manual" position	Switch the solenoid to "Auto" position
		No pressure on the main command tube line	Rinse and clean the command line filter (if it exists), otherwise check the finger filter for blockage and clean as required
		The controller is in "Fault" mode	Please see ADI-P controller manual
5	The flush valve remains open	Air in the valve's command line or control tube is disconnected	<ol style="list-style-type: none"> Bleed air from the control tubing Reconnect control tube Replace control tube if damaged Electronic controller – check the solenoid, bleed the command line, and verify that the controller is not in "Flushing" mode
		The solenoid is set in "Manual" position	Switch the solenoid to "Auto" position
		Controller programmed for a very long flush duration (electronic controller)	Reset "Flush Duration" set point to 10 seconds
		Blocked flushing port	Remove any blockage from the flushing port

Amiad Limited Warranty

1. This certificate applies to Amiad Water Systems Ltd. ("Amiad") products purchased by you (the "Buyer") from Amiad unless specifically agreed otherwise in writing by Amiad. This Warranty extends only to the original purchaser, and is not transferable to anyone who subsequently purchases, leases, or otherwise obtains the product from the original purchaser.
2. Amiad hereby warrants that the products are and will be free from defects in material and workmanship under normal use and service. Amiad warrants that it will correct manufacturing defects in the products, in accordance with the conditions set out in this Warranty.
3. This Warranty is enforceable for a period of 12 months after the date upon which the products were delivered (the "Warranty Period").
4. In the event that during the Warranty Period the Buyer discovers a defect in material and/or workmanship in any product or part (the "Defective Product"), it shall submit a written complaint to Amiad using Amiad's standard Buyer Complaint Form. For the receipt of the Buyer Complaint Form, the submission of the complaint or any questions please contact your service representative.
5. Upon written demand by Amiad the Buyer shall return the Defective Product - or a sample thereof - to Amiad, at Amiad's cost. If the Buyer ships any such Defective Product, Amiad suggests the Buyer package it securely and insure it for value, as Amiad assumes no liability for any loss or damage occurring during shipment. Provided however that in the event Amiad determines that this Warranty does not apply to such product, Buyer shall promptly reimburse Amiad for such cost (including freight and customs). Any returned product or part must be accompanied by the Warranty certificate and the purchase invoice. It is clarified that the Buyer may not return the Defective Product unless such return was coordinated and approved by Amiad in advance.
6. Amiad's obligation under this Warranty shall be limited to, at Amiad's option, the repair or exchange, free of charge, of the product or any part which may prove defective under normal use and service during the Warranty Period. The provision of a repair or replacement of a product during the Warranty Period will result in an extension of the Warranty Period by an additional period of 12 months, provided that the total accumulated Warranty Period shall in any event be no more than 18 months from the date upon which the products were delivered.
7. This Warranty is valid on the condition that the products are installed according to Amiad's instructions as expressed in Amiad's instruction manuals and according to the technical limitations as stipulated in Amiad's literature or as stated by a representative of Amiad.
8. This Warranty will not apply to damaged or defective products resulting from or related to:
 - (i) Fire, flood, power surges or failures or any other catastrophe and/or unforeseen occurrence, such as but not limited to those for which the Buyer is customarily insured for, or any force majeure events;
 - (ii) Fault, abuse or negligence of the Buyer;
 - (iii) Intake water not meeting the agreed standards, as set forth in a written document, approved by Amiad, or improper storage;
 - (iv) Improper or unauthorized use of the product or related parts by the Buyer, including Buyer's failure to operate the product in conformity with the recommendations and instructions of Amiad, as set forth in Amiad's manuals and other written materials, the operation of the product other than by a trained and qualified operator, or improper installation of the product by a third party not authorized by Amiad;
 - (v) Performance by the Buyer of maintenance or operation other than in conformity with the recommendations and instructions of Amiad, or other than in accordance with procedures defined in the literature supplied for products (including the timely replacement of requisite parts), and for services provided other than by a trained and qualified advanced operator; or
 - (vi) Any alteration, modification, foreign attachment to or repair of the products, other than by Amiad or its authorized technical representatives.
9. In no event shall Amiad be liable to the Buyer or any third party for any damages to property, or for any intangible or economic loss, including loss of profits, loss of customers or damage to reputation, for any damages, including indirect, special, consequential damages, or punitive damage arising out of or in connection with this Warranty, or arising out of or in connection with the product's performance or failure to perform, even if it has been advised of the possibility of such damages.
10. Amiad will be excused for failure to perform or for delay in performance hereunder if such failure or delay is due to causes beyond its reasonable control or force majeure preventing or hindering performance.
11. This Warranty set forth herein is the only contractual warranty given by Amiad and is provided in lieu of any other warranties created by any documentation, packaging or otherwise.
12. Amiad makes no warranty whatsoever in respect to accessories or parts not supplied by Amiad. In the event that Amiad is required to correct a Defective Product or product not covered by this Warranty, it will do so solely in consideration for additional fees.
13. The parties will actively endeavor to amicably settle any dispute arising between them. In the event that the parties are unable to reach an equitable settlement of such dispute, any claim or lawsuit related to the Warranty, its validity execution, its performance be brought before only the courts of Tel-Aviv, Israel. Israeli law will govern the Warranty, to the exclusion of any conflict of law rules.



Amiad Water Systems Ltd. D.N. Galil Elyon 1, 1233500, Israel.

Tel: +972 4690 9500 | Fax: +972 48141159 | Email: info@amiad.com

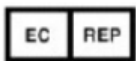

Obelis s.a. Bd Général Wahis 53, 1030 Brussels, Belgium.

Tel: +(32) 2732 5954 | Fax: +(32) 27326003 | Email: mail@obelis.net

EC Declaration https://www.amiad.com/certificatesDownload_CE.asp



www.amiad.com